

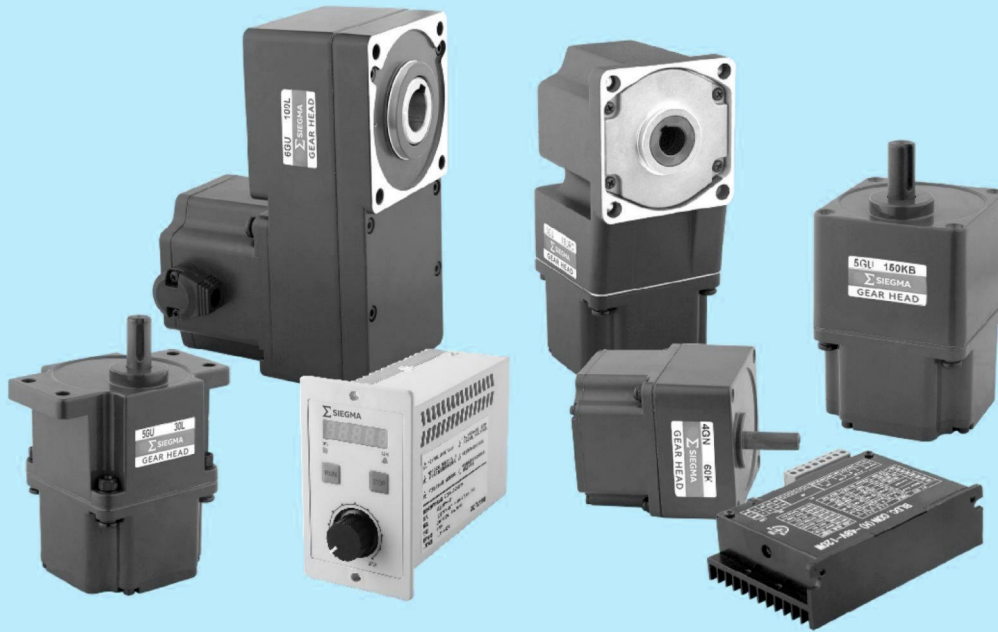

DC BRUSHLESS GEAR MOTOR

DC BRUSHLESS GEAR MOTOR

Easy and simple to achieve speed control.



● Controller

● DC brushless parallel shaft gearmotor

● L type brushless DC gearmotor

Description of brushless DC motor characteristic curve

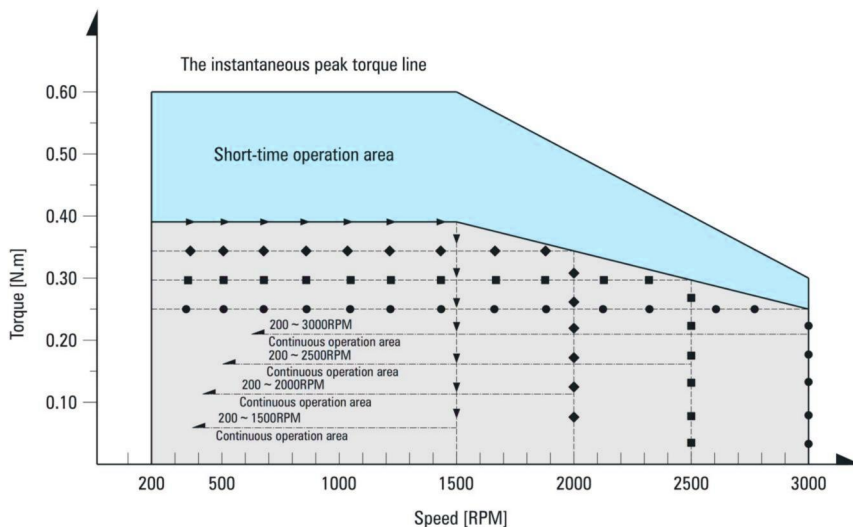

- **The instantaneous maximum torque line:** The maximum torque during motor start-up and instantaneous impact load; exceeding this torque value will cause the driver's overcurrent protection to trip, resulting in a shutdown.
- **Short-time operation area:** When the motor at different speed, it can operate in a short time during this torque range. but after a long time it can cause heating of the motor, resulting motor break or drive overheat protection start, cause stopping working.
- **Rated operation torque line:** At different speeds, the motor can run for a long time.
- **In continuous operation area:** At different speed, the motor can operate.

PRODUCT FEATURES

The characteristics of brushless motor

About brushless motors, there is no need to use mechanical contacts such as brushes and commutators, which are commonly considered drawbacks of DC motors. DC motors use brushes and commutators to rotate, thus requiring regular maintenance. In contrast, brushless motors utilize signals detected by Hall ICs and rotate by the ON/OFF of transistors in the drive circuit, eliminating the need for maintenance.

Stable speed control

Brushless motors continuously compare the set speed with the speed feedback signal from the motor to adjust the voltage applied to the motor. Therefore, even if the load condition changes, they can instantly adjust from low speed to the set speed and operate at this stable speed. Three-phase induction motors controlled by a frequency converter do not perform feedback control, so when the load increases, the speed will drop significantly. For applications that require high speed stability, it is recommended to use brushless motors.

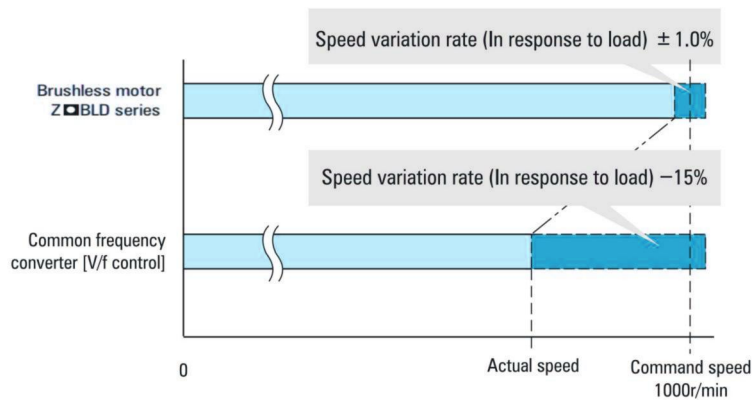

Wide speed control range

Brushless motors have a wider speed control range compared to AC adjustable-speed motors and frequency converters. Since they do not have torque limitations at low speeds as seen with AC adjustable-speed motors, brushless motors are suitable for applications that require a certain amount of torque from low speeds to high speeds.

Product style	Speed control range	Rate ratio
Brushless motor	80~3000	50
Frequency converter control Three phase induction motor	200~2400	12
AC adjustable-speed motors	50Hz: 90~1400	15
	60Hz: 90~1600	17

Saving energy

The rotor of the brushless motor utilizes permanent magnets, which can reduce secondary losses of the rotor. Therefore, compared to three-phase induction motors controlled by frequency conversion, brushless motors consume about 23% less power, contributing to energy savings in devices.

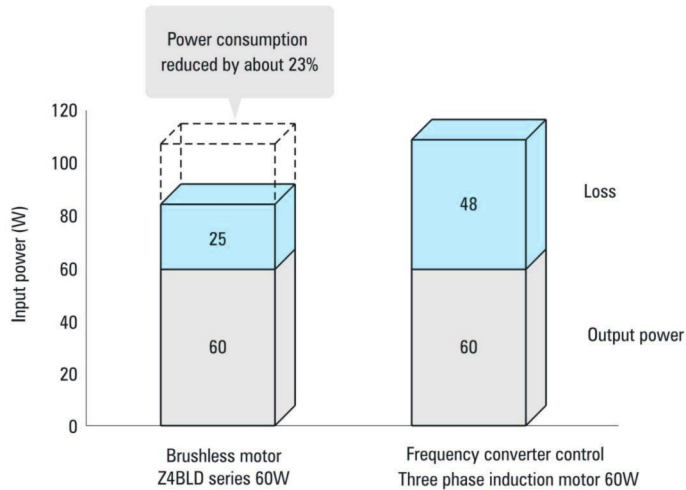

Low speed and high torque performance

DC brushless motor have a steady big torque when running at low speed.

● Z5BLD120-220GU-30S Diagram (SIEGMA standard drive)

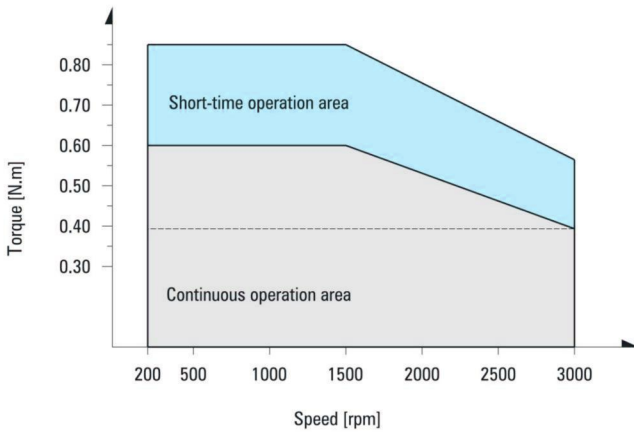

● 5K120RGU-CF (220V/50Hz) (SIEGMA standard drive)

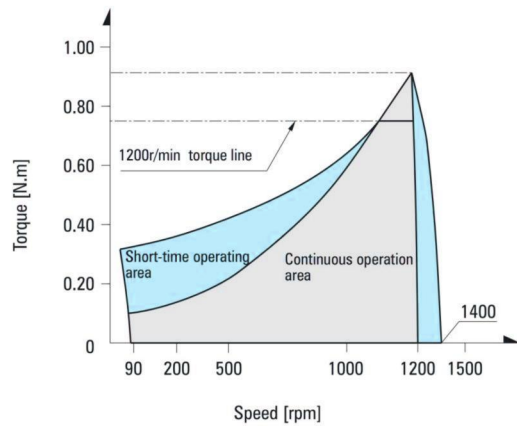

● Working performance table of brushless motor and ac speed adjustable motor

No.	Z5BLD120-220GU-25S					5K120RGU-CF				
	Torque N.m	Speed rpm	Current A	Efficiency %	Temperature rise K	Torque N.m	Speed rpm	Current A	Efficiency %	Temperature rise K
1	0.595	200	0.485	26.5	≤50K	0.010	200	0.850	3.00	≤80K
2	0.595	500	0.671	47.5	≤50K	0.150	500	1.070	8.00	≤80K
3	0.595	1000	0.966	62.0	≤40K	0.500	1000	1.186	32.5	≤80K
4	0.595	1500	1.200	69.0	≤40K	0.915	1400	0.981	60.0	≤55K

Ambient temperature -10°C~+40°C

Thin, high power

Brushless DC motors have a slim body and provide high power due to permanent magnets being used in the rotor. For example, the overall length is 75mm shorter and the output power is 1.3 times higher than that of three-phase induction motors with a frame size of 90mm. Using brushless DC motors can contribute to downsizing and space saving.

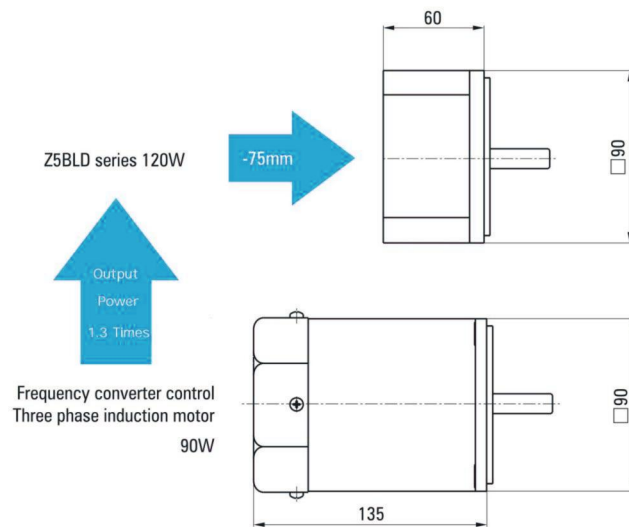

Protection function, help to protect the safety of the equipment system



Due to the load of the overcurrent, undervoltage, open phase protection, Our motor and driver can ensure the safety of equipment system.

Motor spec——Speed

Motor speed	Output shaft speed	Reduction ratio											
		3	3.6	5	6	7.5	9	10	12.5	15	18	20	25
200~1500RPM		67~500	56~417	40~300	33~250	27~200	22~167	20~150	16~120	13~100	11~83	10~75	8~60
2000RPM		667	556	400	334	267	222	200	160	133	111	100	80
2500RPM		833	694	500	417	333	278	250	200	167	139	125	100
3000RPM		1000	833	600	500	400	333	300	240	200	167	150	120

Motor speed	Output shaft speed	Reduction ratio											
		30	36	50	60	75	90	100	120	150	180	200	
200~1500RPM		7~50	6~42	4~30	3~25	3~20	2~17	2~15	2~12.5	1.5~10	1~8	1~7.5	
2000RPM		67	56	40	33	27	22	20	17	13	11	10	
2500RPM		83	69	50	42	33	28	25	21	17	14	13	
3000RPM		100	83	60	50	40	33	30	25	20	17	15	

Motor spec——Product type

Motor	Square size	Output power	Model	Driver	Voltage supply
	60X60	15、25	Standard type IP40 or IP54		DC24~48 Single phase 100~120V Single phase 220~240V
	70X70	30、40			
	80X80	40、60			
	90X90 (GN)	40、60			
	90X90 (GU)	60、90、120			
	104X104	200、400			
	120X120	750、1000			

Motor spec — Basic performance

Item	Motor	Driver
Insulation Resistance (Do not test when the motor is connected to the drive.)	In a constant temperature and humidity environment, after continuous operation, the measured value between the motor winding and the casing using a DC 500V ohmmeter should be above 50MΩ.	After continuous operation in a constant temperature and humidity environment, the resistance between the power terminals and the protective ground terminals, as well as between the power terminals and the input/output signal terminals, should be measured to be above 50MΩ using a DC 500V ohmmeter.
Dielectric Withstand Voltage (Testing is not allowed with the motor connected to the drive.)	After continuous operation in a constant temperature and humidity environment, applying a 50Hz AC voltage of 1.5kV between the winding and the casing for 1 minute should result in no abnormalities, with a leakage current of less than 10mA.	After continuous operation in a constant temperature and humidity environment, no abnormalities should occur when a 50Hz AC voltage of 1.5kV is applied for 1 minute between the power terminals and the protective ground terminals, as well as between the power terminals and the input/output signal terminals.
Temperature rise	After continuous operation in a constant temperature and humidity environment, the temperature rise of the winding measured by the thermocouple method should be below 55°C, and the temperature rise of the outer shell surface should be below 40°C.	After continuous operation in a constant temperature and humidity environment, the temperature rise of the aluminum heat sink measured by the thermocouple method should be below 50°C.
Operating Environment	Ambient Temperature	-10°C ~ +40°C (Icing-Free)
	Humidity	Below 85% (Frost-Free)
	Altitude	Below 1000m
	Medium Environment	Free from corrosive gases and dust; not to be used in special environments containing radioactive materials, magnetic fields, and vacuum
	Vibration	Continuous vibration or excessive shock should not be applied
Storage Environment ②	Ambient Temperature	-10°C ~ +40°C (Icing-Free)
	Humidity	85% or less (Frost-Free)
	Altitude	Below 1000m
Thermal Class	Class B	/
Protection level	IP40 & IP54	IP20

① To maintain the surface temperature of the electric motor casing below 90°C, the motor should be mounted on a heat sink (material: aluminum) of the following dimensions; for a 25W motor: 115mm x 115mm x 5mm thickness, for a 60W motor: 135mm x 135mm x 5mm thickness, for a 120W motor: 165mm x 165mm x 5mm thickness, and for a 200W motor: 200mm x 200mm x 5mm thickness. (Unit: mm)

② The storage condition applies to a short period such as a period during transportation.

PRODUCT CODE

Motor

Z 5 BLD 90 - 220 GN(L) - 30S - M
 ① ② ③ ④ ⑤ ⑥ ⑦ ⑧

①	Company	SIEGMA					
②	Model & Dimension						
	Frame code	2	3	4	5	6	7
	Mounting flange mm	<input type="checkbox"/> 60	<input type="checkbox"/> 70	<input type="checkbox"/> 80	<input type="checkbox"/> 90	<input type="checkbox"/> 104	<input type="checkbox"/> 120
	Housing dimension	60*60	70*70	80*80	90*90	104*104	120*120
③	Motor type	BLD: DC Brushless gear motor					
④	Output power (W)	(e.g) 90: 90W					
⑤	Voltage	(e.g) 24: 24VDC (Optional voltage 24V~48VDC, single phase 100V~120VAC, single phase 220V~240VAC, 50/60Hz)					
⑥	Relative to square type gear box: Motor shaft type	GN: GN type gear shaft GU: GU type gear shaft					
	L type gearbox: Shaft shape	GNL: Type L GN series gear shaft (Mainly for 2&4 series) GUL: Type L GU series gear shaft (Mainly for 5&6 series)					
	Shaft type for only motor: A: Round shaft type	A1: Keyway type					
⑦	Motor speed						
⑧	Motor parts	M: Electromagnetic brake BM: Closed loop feedback mode, generally refers to the motor to increase the encoder (Including the simple holzer encoder)					

Square shape gearbox

5 GN 50 K
 ① ② ③ ④

①	Gearhead frame size	2: 60mm 3: 70mm 4: 80mm 5: 90mm 6: 104mm 7: 120mm
②	Gear type	GN: GN type gear GU: GU type gear
③	Gear ratio	(e.g) 50: Reduction ratio
④	Bearing type	K: Ball bearing (On the GU type square box marked as KB)

Right Angle/ L type gearbox

5 GU 50 LC
 ① ② ③ ④

①	Gearhead frame size	2: 60mm 3: 70mm 4: 80mm 5: 90mm 6: 104mm 7: 120mm
②	Gear type	GN: Type GN gear shaft (For L series 2&4) GU: Type GU gear shaft (For L series 5&6)
③	Gear ratio	(e.g) 50: Reduction ratio
④	Bearing type	LC: L type hollow shaft output reducer RC: Hollow shaft output of spiral bevel gear RT: Solid shaft output of spiral bevel gear

60 SERIES OF BRUSHLESS DC MOTOR

Basic characteristics of motor

● 25W (DC power supply is suitable for 24VDC/36VDC/48VDC)

Rated power (Continuous)		W	25 (15W/25W)		
Rated speed		r/min	3000		
Rated torque		N.m	0.08		
Instantaneous maximum torque		N.m	0.12		
Rotor moment of inertia		J:10 ⁻⁴ kg.m ²	0.042		
Speed control range		RPM	200~3000		
Speed control range	On load	Below ±1%: Condition 0~rated torque, rated speed, rated voltage, room temperature			
	On voltage	Below ±1%: Condition rated voltage ±10%, rated speed, rated load, room temperature			
	On temperature	Below ±1%: Conditions of ambient temperature -10°C~+40°C rated voltage, rated load and rated speed			
Power input	Rated voltage	V	Single phase 110V	Single phase 220V	24VDC (Optional 36VDC/48VDC)
	Voltage tolerance range		±10%		
	Frequency	Hz	50/60		/
	Frequency tolerance range		±5%		
	Rated input current	A	1.0	0.6	1.7
	Instantaneous maximum input current	A	2.0	1.2	2.6

Round shaft type only motor

● Z2BLD25-□A-30S □— Voltage 24/36/48/110/220

● Z2BLD25-220A-30S Diagram (SIEGMA standard drive)

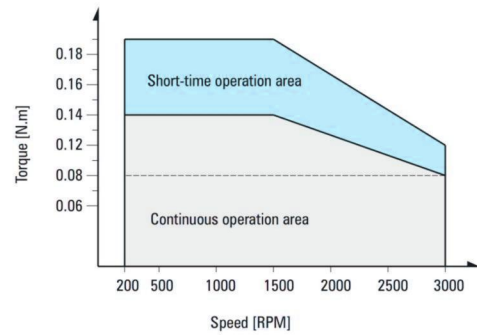
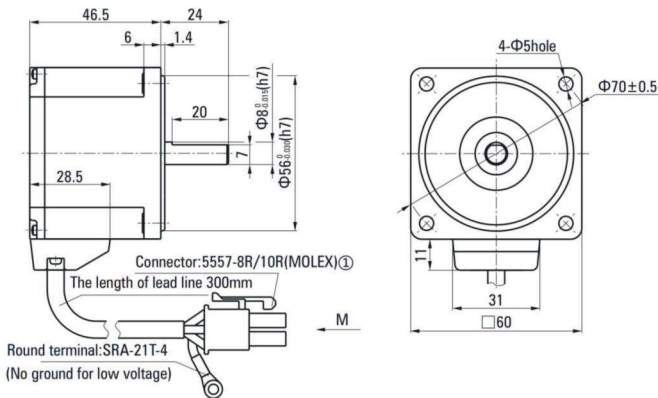

● Low voltage wire plughole corresponding signal explanation

● High voltage wire plughole corresponding signal explanation



25W

Parallel shaft gearbox

Z2BLD25-□GN-30S/2GN□K

□— Voltage 24/36/48/110/220
□— Reduction ratio

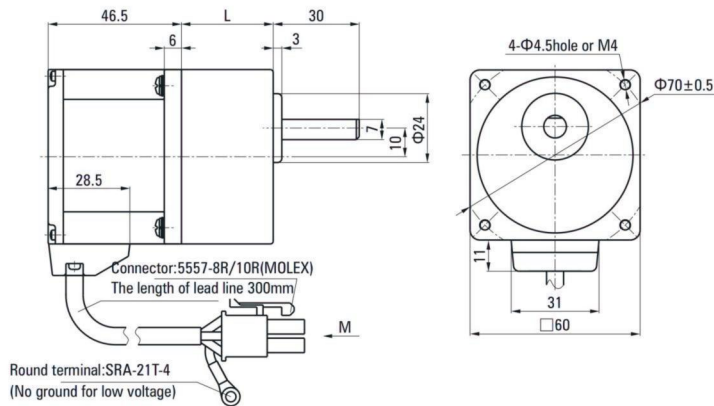

Round terminal: SRA-21T-4
(No ground for low voltage)

Decimal gearbox

2GN□XK

□— Velocity ratio value, generally 10

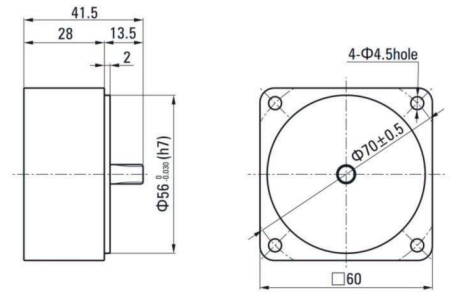

Gearhead model	Gear ratio	L Dimension
2GN□K	3~18	32&41
	20~200	41

□ means gearbox ratio

Z2BLD15-□GN-30S/2GN□K gearmotor allowable torque (Unit: N.m)

Model	Reduction ratio	Motor speed																							
		3	3.6	5	6	7.5	9	10	12.5	15	18	20	25	30	36	50	60	75	90	100	120	150	180	200	
Z2BLD15-□GN	200~1500RPM	0.18	0.22	0.30	0.36	0.45	0.54	0.60	0.75	0.91	1.08	1.09	1.36	1.63	1.96	2.72	3.00	3.00	3.00	3.00	3.00	3.00	3.00	3.00	3.00
	2000RPM	0.15	0.18	0.26	0.31	0.38	0.45	0.51	0.64	0.77	0.92	0.92	1.15	1.38	2.30	2.50	3.00	3.00	3.00	3.00	3.00	3.00	3.00	3.00	3.00
	2500RPM	0.14	0.17	0.23	0.28	0.35	0.42	0.46	0.58	0.70	0.84	0.84	1.05	1.25	1.51	2.09	2.27	2.83	3.00	3.00	3.00	3.00	3.00	3.00	3.00
	3000RPM	0.12	0.14	0.19	0.23	0.29	0.35	0.39	0.48	0.58	0.70	0.70	0.87	1.05	1.25	1.74	1.88	2.35	2.82	3.00	3.00	3.00	3.00	3.00	3.00

Z2BLD25-□GN-30S/2GN□K gearmotor allowable torque (Unit: N.m)

Model	Reduction ratio	Motor speed																							
		3	3.6	5	6	7.5	9	10	12.5	15	18	20	25	30	36	50	60	75	90	100	120	150	180	200	
Z2BLD25-□GN	200~1500RPM	0.30	0.36	0.50	0.60	0.75	0.91	1.00	1.26	1.51	1.81	1.81	2.27	2.72	3.00	3.00	3.00	3.00	3.00	3.00	3.00	3.00	3.00	3.00	3.00
	2000RPM	0.26	0.31	0.43	0.51	0.64	0.77	0.85	1.06	1.28	1.53	1.53	1.92	2.30	2.76	3.00	3.00	3.00	3.00	3.00	3.00	3.00	3.00	3.00	3.00
	2500RPM	0.23	0.28	0.39	0.46	0.58	0.69	0.77	0.97	1.16	1.39	1.39	1.74	2.09	2.51	3.00	3.00	3.00	3.00	3.00	3.00	3.00	3.00	3.00	3.00
	3000RPM	0.19	0.23	0.32	0.39	0.48	0.58	0.64	0.81	0.97	1.16	1.16	1.45	1.74	2.09	2.90	3.00	3.00	3.00	3.00	3.00	3.00	3.00	3.00	3.00

Note : The (Grey background area) in the table indicates that the rotation direction is same as the motor. (The torque under different speed and speed ratio is obtained under the SIEGMA standard.)

L type gearbox

Z2BLD25-□GNL-30S/2GN□LC

□— Voltage 24/36/48/110/220
□— Reduction ratio

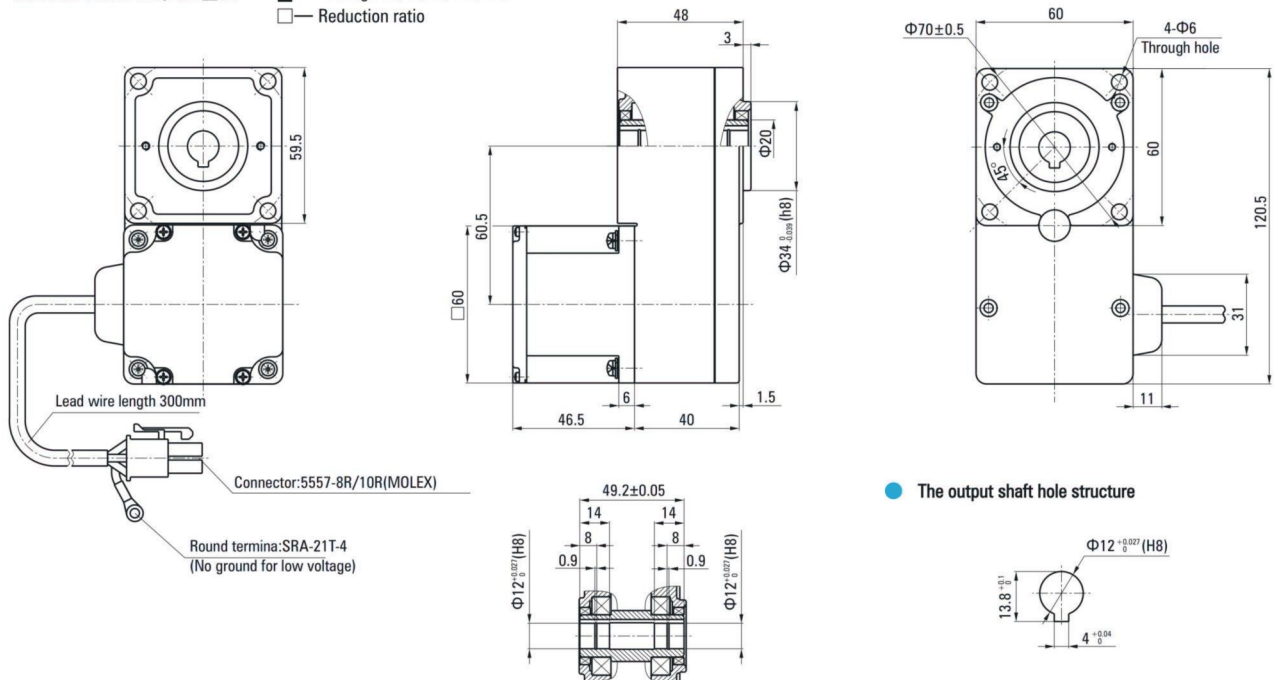

The output shaft hole structure

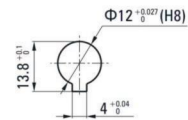

● Z2BLD15-□GNL-30S/2GN□LC gearmotor allowable torque (Unit: N.m)

Reduction Ratio Motor Speed	Reduction Ratio							
	5	10	15	20	30	50	100	200
200~1500RPM	0.27	0.54	0.82	1.09	1.63	2.72	5.44	10.9
2000RPM	0.23	0.46	0.69	0.92	1.38	2.30	4.60	9.20
2500RPM	0.21	0.42	0.63	0.84	1.25	2.09	4.18	8.37
3000RPM	0.17	0.35	0.52	0.70	1.05	1.74	3.49	6.97

Note : All gearbox output turn direction in form are opposite motor turn direction. (The torque under different speed and speed ratio is obtained under the SIEGMA standard.)

● Z2BLD25-□GNL-30S/2GN□LC gearmotor allowable torque (Unit: N.m)

Reduction Ratio Motor Speed	Reduction Ratio							
	5	10	15	20	30	50	100	200
200~1500RPM	0.50	1.00	1.51	2.01	2.72	4.53	9.06	16.40
2000RPM	0.43	0.85	1.28	1.70	2.30	3.83	7.67	13.90
2500RPM	0.39	0.77	1.16	1.55	2.09	3.49	6.97	12.60
3000RPM	0.29	0.58	0.87	1.16	1.74	2.90	5.81	11.62

Note : All gearbox output turn direction in form are opposite motor turn direction. (The torque under different speed and speed ratio is obtained under the SIEGMA standard.)

70 SERIES OF BRUSHLESS DC MOTOR

Basic characteristics of motor

- 40W (DC power supply is suitable for 24VDC/36VDC/48VDC)

Rated power (Continuous)	W	40 (40W)			
Rated speed	r/min	3000			
Rated torque	N.m	0.127			
Instantaneous maximum torque	N.m	0.191			
Rotor moment of inertia	J: $\times 10^{-4} \text{kg.m}^2$	0.082			
Speed control range	RPM	200~3000			
Speed control range	On load	Below $\pm 1\%$: Condition 0~rated torque, rated speed, rated voltage, room temperature			
	On voltage	Below $\pm 1\%$: Condition rated voltage $\pm 10\%$, rated speed, rated load, room temperature			
	On temperature	Below $\pm 1\%$: Conditions of ambient temperature $-10^\circ\text{C} \sim +40^\circ\text{C}$ rated voltage, rated load and rated speed			
Power input	Rated voltage	V	24VDC (Optional 36VDC/48VDC)		
	Voltage tolerance range		$\pm 10\%$		
	Frequency	Hz	50/60	/	
	Frequency tolerance range		$\pm 5\%$		
	Rated input current	A	1.7	1.0	3.7
	Instantaneous maximum input current	A	3.3	1.9	5.6

Round shaft type only motor

- Z3BLD40-A-30S —Voltage 24/36/48

- Z3BLD40-220A-30S Diagram (SIEGMA standard drive)

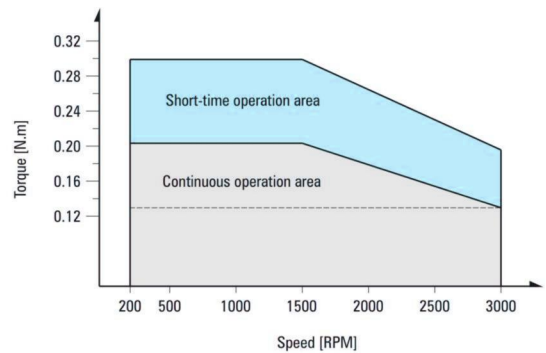
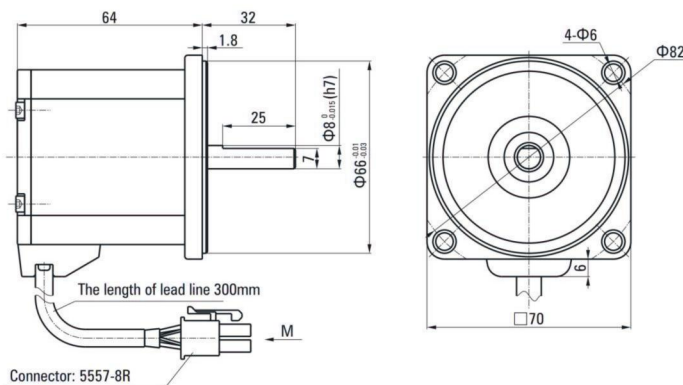

- Low voltage wire plughole corresponding signal explanation

- High voltage wire plughole corresponding signal explanation



40W

Parallel shaft gearbox

Z3BLD40-□GN-30S/3GN□K □ — Voltage 24/36/48
 □ — Reduction ratio

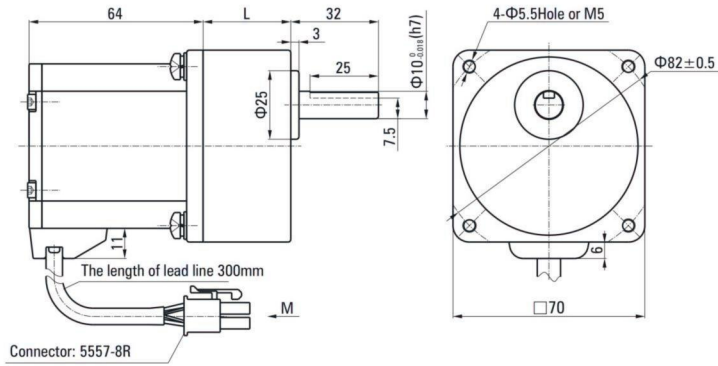

Key · Keyway

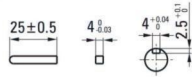

Decimal gearbox

3GN□XK □ — Velocity ratio value, generally 10

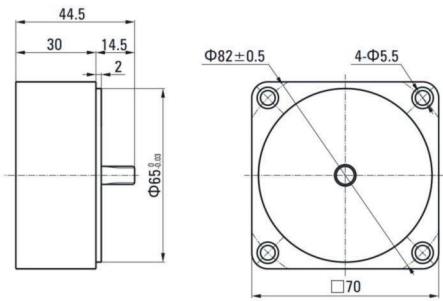

Gearhead model	Gear ratio	L Dimension
3GN□K	3~18	32&42
	20~200	42

□ means gearbox ratio

Z3BLD40-□GN-30S/3GN□K gearmotor allowable torque (Unit: N.m)

Model	Reduction ratio	Motor speed																						
		3	3.6	5	6	7.5	9	10	12.5	15	18	20	25	30	36	50	60	75	90	100	120	150	180	200
Z3BLD40-□GN	200~1500RPM	0.48	0.58	0.80	0.97	1.21	1.45	1.61	2.01	2.41	2.90	2.90	3.63	4.35	5.00	5.00	5.00	5.00	5.00	5.00	5.00	5.00	5.00	5.00
	2000RPM	0.41	0.49	0.68	0.82	1.02	1.23	1.36	1.70	2.04	2.45	2.45	3.07	3.68	4.42	5.00	5.00	5.00	5.00	5.00	5.00	5.00	5.00	5.00
	2500RPM	0.37	0.45	0.62	0.74	0.93	1.11	1.24	1.55	1.86	2.23	2.23	2.79	3.35	4.02	5.00	5.00	5.00	5.00	5.00	5.00	5.00	5.00	5.00
	3000RPM	0.31	0.37	0.52	0.62	0.77	0.93	1.03	1.29	1.55	1.86	1.86	2.32	2.79	3.35	4.65	5.00	5.00	5.00	5.00	5.00	5.00	5.00	5.00

● L type gearbox

Z3BLD40-□GNL-30S/3GN□LC □— Voltage 24/36/48
 □— Reduction ratio

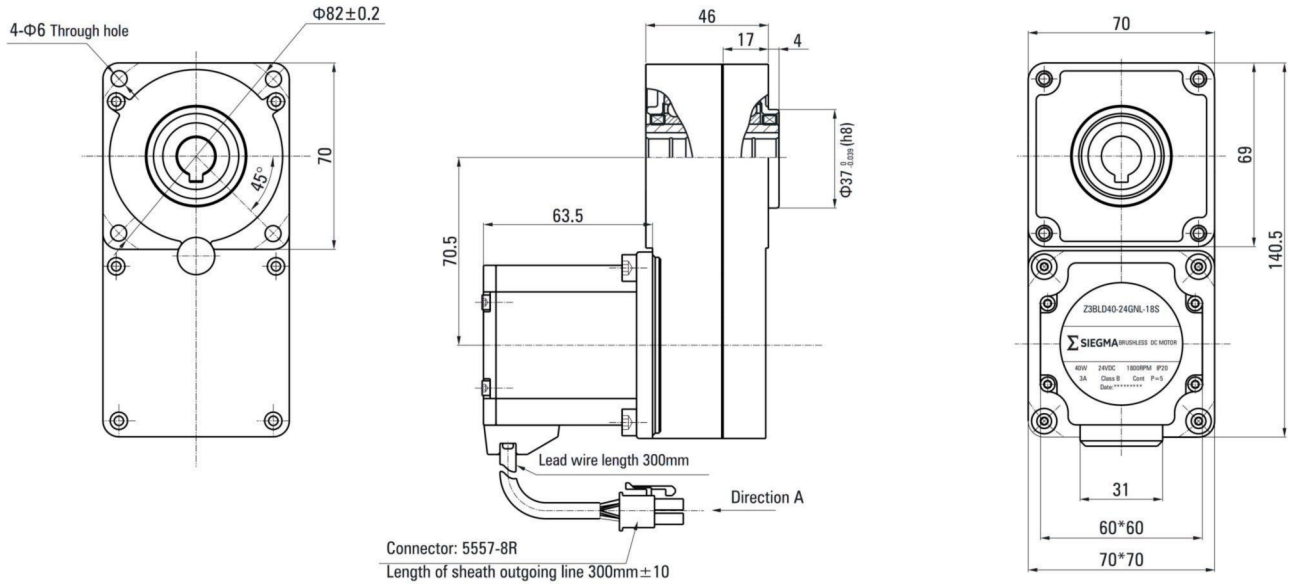

● The output shaft hole structure

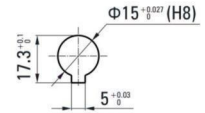

● Z3BLD40-24GNL-18S/3GN□LC gearmotor allowable torque (Unit: N.m)

Reduction ratio	5	10	15	20	30	50	60	90	100
Motor speed									
1800RPM	0.77	1.55	2.32	3.10	4.65	7.75	9.30	13.94	15.49
3000RPM	0.46	0.93	1.39	1.86	2.79	4.65	5.58	8.37	9.30

Note : All gearbox output turn direction in form are opposite motor turn direction.(The torque under different speed and speed ratio is obtained under the SIEGMA standard.)

● Z3BLD60-24GNL-18S/3GN□LC gearmotor allowable torque (Unit: N.m)

Reduction ratio	5	10	15	20	30	50	60	90	100
Motor speed									
1800RPM	1.16	2.32	3.49	4.65	6.97	11.62	13.94	20.91	23.24
3000RPM	0.70	1.39	2.09	2.79	4.18	6.97	8.37	12.55	13.94

Note : All gearbox output turn direction in form are opposite motor turn direction. (The torque under different speed and speed ratio is obtained under the SIEGMA standard.)

80 SERIES OF BRUSHLESS DC MOTOR

Basic characteristics of motor

● 60W (DC power supply is suitable for 24VDC/36VDC/48VDC)

Rated power (Continuous)	W	60 (40W/60W)			
Rated speed	r/min	3000			
Rated torque	N.m	0.191			
Instantaneous maximum torque	N.m	0.287			
Rotor moment of inertia	J: $\times 10^{-4} \text{kg.m}^2$	0.082			
Speed control range	RPM	200~3000			
Speed control range	On load	Below $\pm 1\%$: Condition 0~rated torque, rated speed, rated voltage, room temperature			
	On voltage	Below $\pm 1\%$: Condition rated voltage $\pm 10\%$, rated speed, rated load, room temperature			
	On temperature	Below $\pm 1\%$: Conditions of ambient temperature $-10^{\circ}\text{C} \sim +40^{\circ}\text{C}$ rated voltage, rated load and rated speed			
Power input	Rated voltage	V	Single phase 110V	Single phase 220V	24VDC (Optional 36VDC/48VDC)
	Voltage tolerance range		$\pm 10\%$		
	Frequency	Hz	50/60	/	
	Frequency tolerance range		$\pm 5\%$		
	Rated input current	A	1.7	1.0	3.7
	Instantaneous maximum input current	A	3.3	1.9	5.6

Round shaft type only motor

● Z4BLD60-□A-30S □—Voltage 24/36/48/110/220

● Z4BLD60-220A-30S Diagram (SIEGMA standard drive)

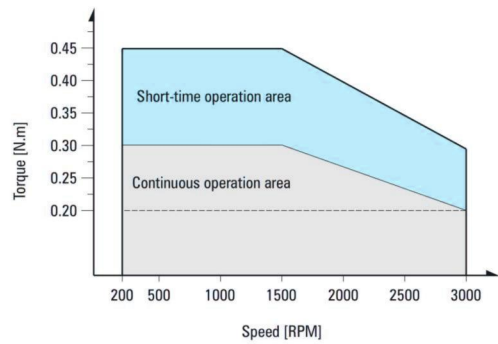
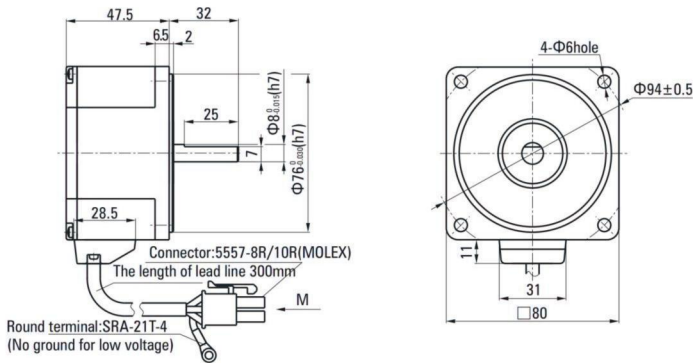

● Low voltage wire plughole corresponding signal explanation

● High voltage wire plughole corresponding signal explanation

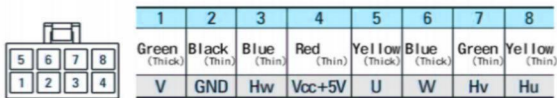

60W

Parallel shaft gearbox

Z4BLD60-□GN-30S/4GN□K

□ — Voltage 24/36/48/110/220
□ — Reduction ratio

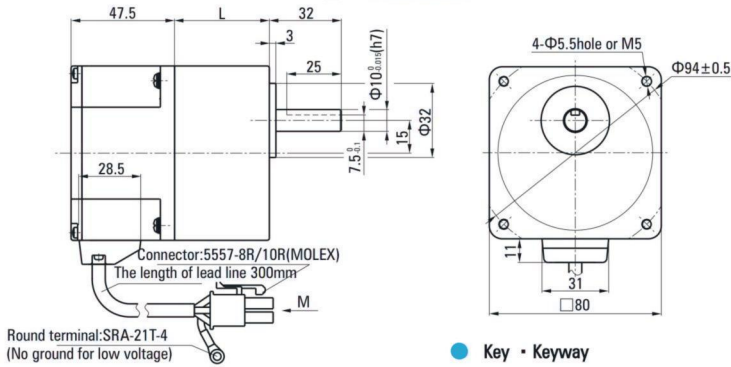

Key • Keyway

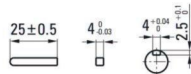

Decimal gearbox

4GN□XK

□ — Velocity ratio value, generally 10

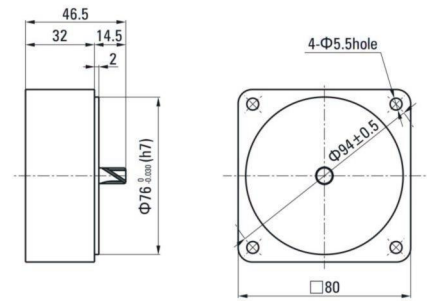

Gearhead model	Gear ratio	L Dimension
4GN□K	3~18	32&43.5
	20~200	43.5

• □ means gearbox ratio

Z4BLD40-□GN-30S/4GN□K gearmotor allowable torque (Unit: N.m)

Model	Reduction ratio	Motor speed																						
		3	3.6	5	6	7.5	9	10	12.5	15	18	20	25	30	36	50	60	75	90	100	120	150	180	200
Z4BLD40-□GN	200~1500RPM	0.48	0.58	0.80	0.97	1.21	1.45	1.61	2.01	2.41	2.90	2.90	3.63	4.35	5.22	7.25	7.87	8.00	8.00	8.00	8.00	8.00	8.00	8.00
	2000RPM	0.41	0.49	0.68	0.82	1.02	1.23	1.36	1.70	2.04	2.45	2.45	3.07	3.68	4.42	6.13	6.66	8.00	8.00	8.00	8.00	8.00	8.00	8.00
	2500RPM	0.37	0.45	0.62	0.74	0.93	1.11	1.24	1.55	1.86	2.23	2.23	2.79	3.35	4.02	5.58	6.05	7.56	8.00	8.00	8.00	8.00	8.00	8.00
	3000RPM	0.31	0.37	0.52	0.62	0.77	0.93	1.03	1.29	1.55	1.86	1.86	2.32	2.79	3.35	4.65	5.01	6.26	7.52	8.00	8.00	8.00	8.00	8.00

Z4BLD60-□GN-30S/4GN□K gearmotor allowable torque (Unit: N.m)

Model	Reduction ratio	Motor speed																						
		3	3.6	5	6	7.5	9	10	12.5	15	18	20	25	30	36	50	60	75	90	100	120	150	180	200
Z4BLD60-□GN	200~1500RPM	0.72	0.87	1.21	1.45	1.81	2.17	2.41	3.02	3.62	4.34	4.35	5.44	6.53	7.83	8.00	8.00	8.00	8.00	8.00	8.00	8.00	8.00	8.00
	2000RPM	0.61	0.74	1.02	1.23	1.53	1.84	2.04	2.55	3.06	3.68	3.68	4.60	5.52	6.63	8.00	8.00	8.00	8.00	8.00	8.00	8.00	8.00	8.00
	2500RPM	0.56	0.67	0.93	1.11	1.39	1.67	1.86	2.32	2.78	3.34	3.35	4.18	5.02	6.02	8.00	8.00	8.00	8.00	8.00	8.00	8.00	8.00	8.00
	3000RPM	0.46	0.56	0.77	0.93	1.16	1.39	1.55	1.93	2.32	2.78	2.79	3.49	4.18	5.02	6.97	7.52	8.00	8.00	8.00	8.00	8.00	8.00	8.00

Note : The (Grey background area) in the table indicates that the rotation direction is same as the motor (The torque under different speed and speed ratio is obtained under the SIEGMA standard.)

L type speed reducer

Z4BLD60-□GNL-30S/4GN□LC

□ — Voltage 24/36/48/110/220
□ — Reduction ratio

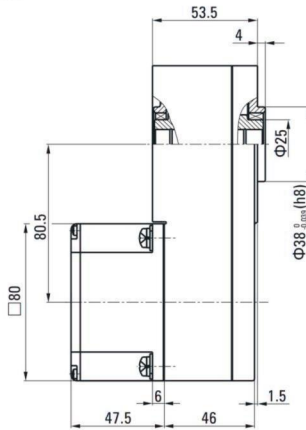
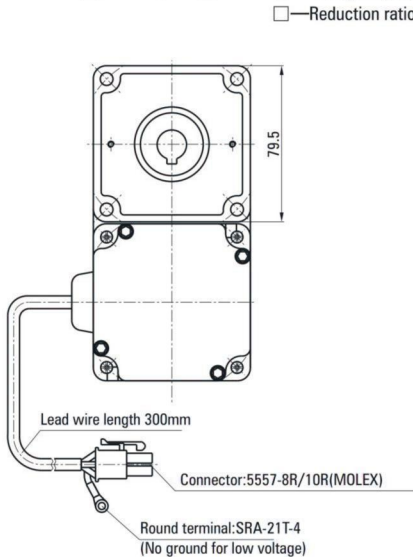

The output shaft hole structure

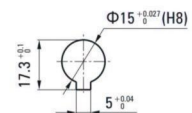
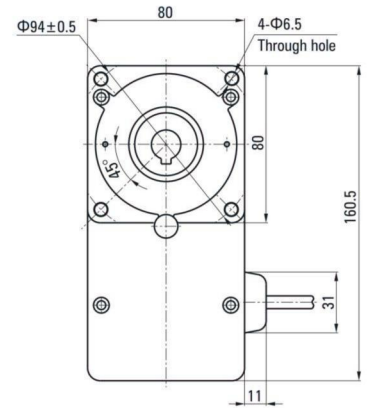

● Z4BLD40-□GNL-30S/4GN□LC gearmotor allowable torque (Unit: N.m)

Reduction ratio	5	10	15	20	30	50	100	200
Motor speed								
200~1500RPM	0.73	1.45	2.18	2.90	4.35	7.25	14.50	29.00
2000RPM	0.61	1.23	1.84	2.45	3.68	6.13	12.30	24.50
2500RPM	0.56	1.12	1.67	2.23	3.35	5.58	11.20	22.30
3000RPM	0.46	0.93	1.39	1.86	2.79	4.65	9.30	18.59

● Z4BLD60-□GNL-30S/4GN□LC gearmotor allowable torque (Unit: N.m)

Reduction ratio	5	10	15	20	30	50	100	200
Motor speed								
200~1500RPM	1.21	2.41	3.62	4.83	6.53	10.9	21.80	39.30
2000RPM	1.02	2.04	3.06	4.08	5.52	9.20	18.40	33.30
2500RPM	0.93	1.86	2.78	3.71	5.02	8.37	16.70	30.30
3000RPM	0.70	1.39	2.09	2.79	4.18	6.97	13.94	27.89

Note : All gearbox output turn direction in form are opposite motor turn direction. (The torque under different speed and speed ratio is obtained under the SIEGMA standard.)

● Arc cone right angle speed reducer motor

Z4BLD60-□GN-30S/4GN□RC □—Voltage 24/36/48/110/220
□—Reduction ratio

Z4BLD60-□GN-30S/4GN□RT □—Voltage 24/36/48/110/220
□—Reduction ratio

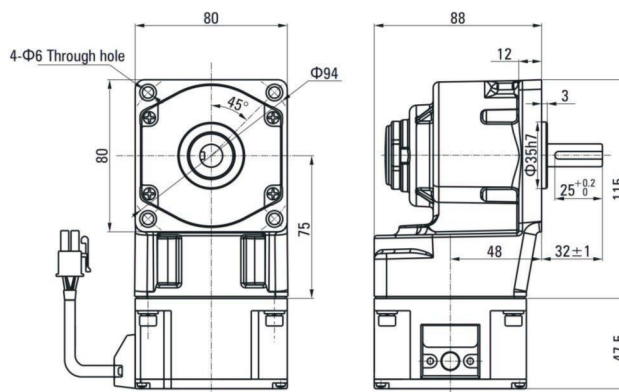
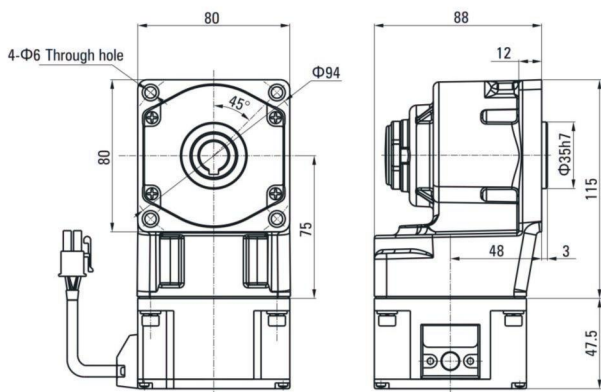

● The output shaft hole structure

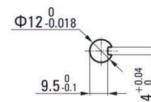
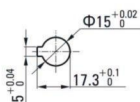

● Z4BLD40-□GN-30S/4GN□RC/RT Machine allowable torque (Unit: N.m)

Model	Reduction ratio	Machine allowable torque (Unit: N.m)																	
		7.5	9	10	12.5	15	18	20	25	30	36	50	60	75	90	100	120	150	180
Z4BLD40-□GN	Motor speed																		
	200~1500RPM	1.21	1.45	1.61	2.01	2.41	2.90	2.90	3.63	4.35	5.22	7.25	7.87	8.00	8.00	8.00	8.00	8.00	8.00
	2000RPM	1.02	1.23	1.36	1.70	2.04	2.45	2.45	3.07	3.68	4.42	6.13	6.66	8.00	8.00	8.00	8.00	8.00	8.00
	2500RPM	0.93	1.11	1.24	1.55	1.86	2.23	2.23	2.79	3.35	4.02	5.58	6.05	7.56	8.00	8.00	8.00	8.00	8.00
	3000RPM	0.63	0.76	0.84	1.05	1.26	1.51	1.68	2.10	2.52	3.03	4.20	5.58	6.97	8.00	8.00	8.00	8.00	8.00

● Z4BLD60-□GN-30S/4GN□RC/RT Machine allowable torque (Unit: N.m)

Model	Reduction ratio	Machine allowable torque (Unit: N.m)																	
		7.5	9	10	12.5	15	18	20	25	30	36	50	60	75	90	100	120	150	180
Z4BLD60-□GN	Motor speed																		
	200~1500RPM	1.81	2.17	2.41	3.02	3.62	4.34	4.35	5.44	6.53	7.83	8.00	8.00	8.00	8.00	8.00	8.00	8.00	8.00
	2000RPM	1.53	1.84	2.04	2.55	3.06	3.68	3.68	4.60	5.52	6.63	8.00	8.00	8.00	8.00	8.00	8.00	8.00	8.00
	2500RPM	1.39	1.67	1.86	2.32	2.78	3.34	3.35	4.18	5.02	6.02	8.00	8.00	8.00	8.00	8.00	8.00	8.00	8.00
	3000RPM	0.95	1.13	1.26	1.58	1.89	2.27	2.52	3.15	3.78	4.54	6.30	8.00	8.00	8.00	8.00	8.00	8.00	8.00

Note : The (gray) in the table indicates that the rotation direction is consistent with the motor. (The torque under different speed and speed ratio is obtained under the SIEGMA standard.)

90 SERIES OF BRUSHLESS DC MOTOR(GN GYPE)

Basic characteristics of motor

- 60W (DC power supply is suitable for 24VDC/36VDC/48VDC)

Rated power (Continuous)	W	60 (40W/60W)			
Rated speed	r/min	3000			
Rated torque	N.m	0.191			
Instantaneous maximum torque	N.m	0.287			
Motor moment of inertia	J: $\times 10^{-4} \text{kg.m}^2$	0.082			
Speed control range	RPM	200~3000			
Speed control range	On load	Below $\pm 1\%$: Condition 0~rated torque, rated speed, rated voltage, room temperature			
	On voltage	Below $\pm 1\%$: Condition rated voltage $\pm 10\%$, rated speed, rated load, room temperature			
	On temperature	Below $\pm 1\%$: Conditions of ambient temperature $-10^{\circ}\text{C} \sim +40^{\circ}\text{C}$ rated voltage, rated load and rated speed			
Power input	Rated voltage	V	Single phase 110V	Single phase 220V	24VDC (Optional 36VDC/48VDC)
	Voltage tolerance range		$\pm 10\%$		
	Frequency	Hz	50/60		/
	Frequency tolerance range		$\pm 5\%$		
	Rated input current	A	1.7	1.0	3.7
	Instantaneous maximum input current	A	3.3	1.9	5.6

Round shaft type only motor

- Z5BLD60-A-30S — Voltage 24/36/48/110/220

- Z5BLD60-220A-30S Diagram (SIEGMA standard drive)

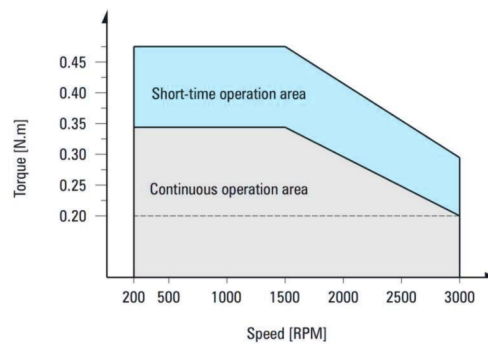
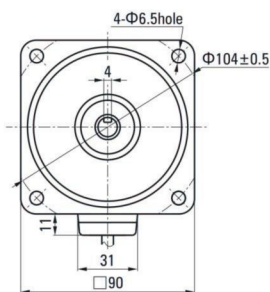
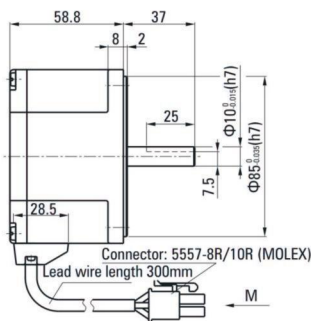

- Low voltage wire plughole corresponding signal explanation

- High voltage wire plughole corresponding signal explanation



60W

Parallel shaft gearbox

Z5BLD60-□GN-30S/5GN□K □ Voltage 24/36/48/110/220
 □ Reduction ratio

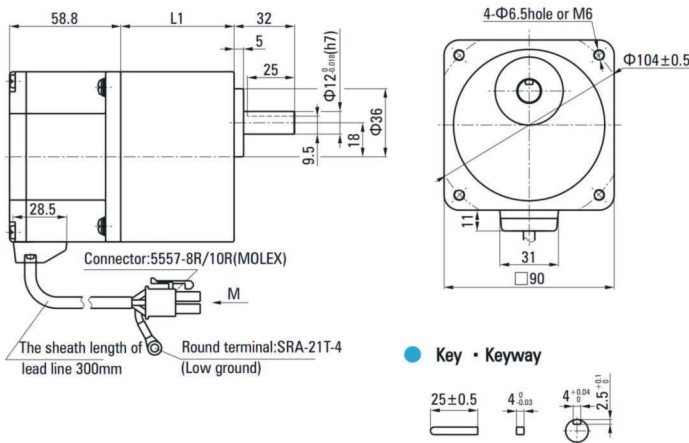

Decimal gearbox

5GN□XK □ Velocity ratio value, generally 10

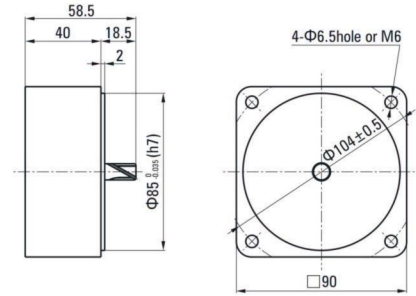

Gearhead model	Gear ratio	L Dimension
5GN□K	3~18	42&60
	20~200	60

□ means gearbox ratio

Z5BLD40-□GN-30S/5GN□K gearmotor allowable torque (Unit: N.m)

Model	Reduction ratio	Motor speed																							
		3	3.6	5	6	7.5	9	10	12.5	15	18	20	25	30	36	50	60	75	90	100	120	150	180	200	
Z5BLD40-□GN	200~1500RPM	0.48	0.58	0.80	0.97	1.21	1.45	1.61	2.01	2.41	2.90	2.90	3.63	4.35	5.22	7.25	7.87	9.83	10.0	10.0	10.0	10.0	10.0	10.0	10.0
	2000RPM	0.41	0.49	0.68	0.82	1.02	1.23	1.36	1.70	2.04	2.45	2.45	3.07	3.68	4.42	6.13	6.66	8.32	9.98	10.0	10.0	10.0	10.0	10.0	10.0
	2500RPM	0.37	0.45	0.62	0.74	0.93	1.11	1.24	1.55	1.86	2.23	2.23	2.79	3.35	4.02	5.58	6.05	7.56	9.08	10.0	10.0	10.0	10.0	10.0	10.0
	3000RPM	0.31	0.37	0.52	0.62	0.77	0.93	1.03	1.29	1.55	1.86	1.86	2.32	2.79	3.35	4.65	5.01	6.26	7.52	8.35	10.0	10.0	10.0	10.0	10.0

Z5BLD60-□GN-30S/5GN□K gearmotor allowable torque (Unit: N.m)

Model	Reduction ratio	Motor speed																							
		3	3.6	5	6	7.5	9	10	12.5	15	18	20	25	30	36	50	60	75	90	100	120	150	180	200	
Z5BLD60-□GN	200~1500RPM	0.72	0.87	1.21	1.45	1.81	2.17	2.41	3.02	3.62	4.34	4.35	5.44	6.53	7.83	9.83	10.0	10.0	10.0	10.0	10.0	10.0	10.0	10.0	10.0
	2000RPM	0.61	0.74	1.02	1.23	1.53	1.84	2.04	2.55	3.06	3.68	3.68	4.60	5.52	6.63	8.32	9.98	10.0	10.0	10.0	10.0	10.0	10.0	10.0	10.0
	2500RPM	0.56	0.67	0.93	1.11	1.39	1.67	1.86	2.32	2.78	3.34	3.35	4.18	5.02	6.02	7.56	9.08	10.0	10.0	10.0	10.0	10.0	10.0	10.0	10.0
	3000RPM	0.46	0.56	0.77	0.93	1.16	1.39	1.55	1.93	2.32	2.78	2.79	3.49	4.18	5.02	6.97	7.52	9.40	10.0	10.0	10.0	10.0	10.0	10.0	10.0

Note : The (Grey background area) in the table indicates that the rotation direction is same as the motor. (The torque under different speed and speed ratio is obtained under the SIEGMA standard.)

90 SERIES OF BRUSHLESS DC MOTOR(GN GYPE)

Basic characteristics of motor

- 120W (DC power supply is suitable for 24VDC/36VDC/48VDC)

Rated power (Continuous)	W	120 (60W/90W/120W)			
Rated speed	r/min	3000			
Rated torque	N.m	0.382			
Instantaneous maximum torque	N.m	0.573			
Rotor moment of inertia	J: 10^{-4} kg.m ²	0.250			
Speed control range	RPM	200~3000			
Speed control range	On load	Below $\pm 1\%$: Condition 0~rated torque, rated speed, rated voltage, room temperature			
	On voltage]Below $\pm 1\%$: Condition rated voltage $\pm 10\%$, rated speed, rated load, room temperature			
	On temperature	Below $\pm 1\%$: Conditions of ambient temperature $-10^{\circ}\text{C} \sim +40^{\circ}\text{C}$ rated voltage, rated load and rated speed			
Power input	Rated voltage	V	Single phase 110V	Single phase 220V	24VDC (Optional 36VDC/48VDC)
	Voltage tolerance range		$\pm 10\%$		
	Frequency	Hz	50/60		/
	Frequency tolerance range		$\pm 5\%$		
	Rated input current	A	3.5	2.0	6.8
	Instantaneous maximum input current	A	7.0	4.5	13.0

Round shaft type only motor

- Z5BLD120-□A-30S □—Voltage 24/36/48/110/220

- Z5BLD120-220A-30S Diagram (SIEGMA standard drive)

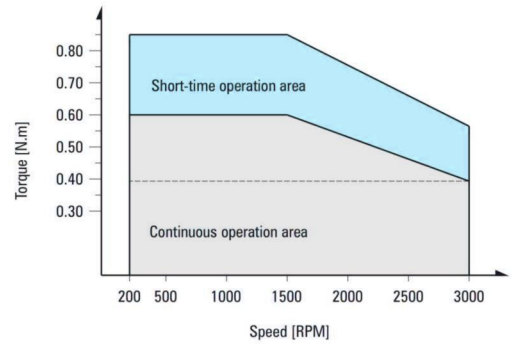
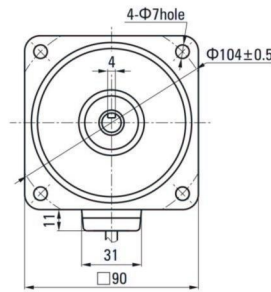
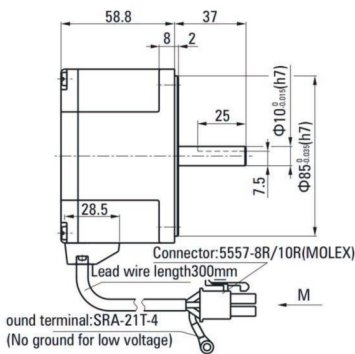

- Low voltage wire plughole corresponding signal explanation

- High voltage wire plughole corresponding signal explanation

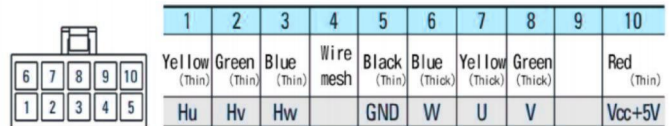

120W

Parallel shaft gearbox

Z5BLD120-□GU-30S/5GU□KB □— Voltage 24/36/48/110/220
□— Reduction ratio

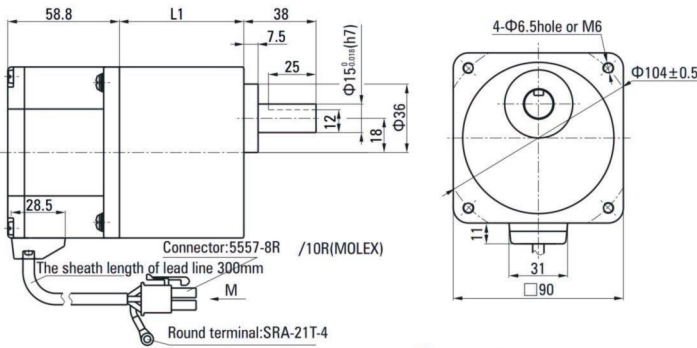

Key - Keyway

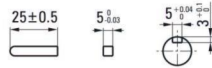

Decimal gearbox

5GU□XK
□— Velocity ratio value, generally 10

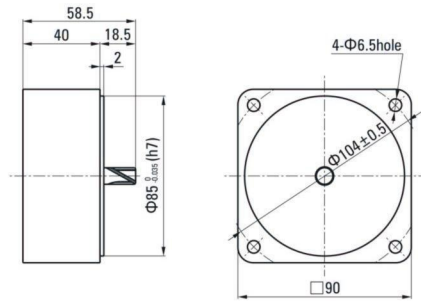

Gearhead model	Gear ratio	L Dimension
5GU□K	3~200	65.5

□ means gearbox ratio

Z5BLD60-□GU-30S/5GU□K gearmotor allowable torque (Unit: N.m)

Model	Reduction ratio	Motor speed																							
		3	3.6	5	6	7.5	9	10	12.5	15	18	20	25	30	36	50	60	75	90	100	120	150	180	200	
Z5BLD60-□GU	200~1500RPM	0.72	0.87	1.21	1.45	1.81	2.17	2.41	3.02	3.62	4.34	4.35	5.44	6.53	7.83	9.83	10.0	10.0	10.0	10.0	10.0	10.0	10.0	10.0	10.0
	2000RPM	0.61	0.74	1.02	1.23	1.53	1.84	2.04	2.55	3.06	3.68	3.68	4.60	5.52	6.63	8.32	9.98	10.0	10.0	10.0	10.0	10.0	10.0	10.0	10.0
	2500RPM	0.56	0.67	0.93	1.11	1.39	1.67	1.86	2.32	2.78	3.34	3.35	4.18	5.02	6.02	7.56	9.08	10.0	10.0	10.0	10.0	10.0	10.0	10.0	10.0
	3000RPM	0.46	0.56	0.77	0.93	1.16	1.39	1.55	1.93	2.32	2.78	2.79	3.49	4.18	5.02	6.97	7.52	9.40	10.0	10.0	10.0	10.0	10.0	10.0	10.0

Z5BLD90-□GU-30S/5GU□K gearmotor allowable torque (Unit: N.m)

Model	Reduction ratio	Motor speed																							
		3	3.6	5	6	7.5	9	10	12.5	15	18	20	25	30	36	50	60	75	90	100	120	150	180	200	
Z5BLD90-□GU	200~1500RPM	1.09	1.30	1.81	2.18	2.72	3.26	3.62	4.53	5.43	6.52	6.53	8.16	9.79	11.8	14.7	17.7	20.0	20.0	20.0	20.0	20.0	20.0	20.0	20.0
	2000RPM	0.92	1.10	1.53	1.84	2.30	2.76	3.06	3.83	4.59	5.51	5.52	6.90	8.28	9.94	12.5	15.0	18.7	20.0	20.0	20.0	20.0	20.0	20.0	20.0
	2500RPM	0.84	1.00	1.39	1.67	2.09	2.51	2.78	3.48	4.18	5.01	5.02	6.27	7.53	9.04	11.3	13.6	17.0	20.0	20.0	20.0	20.0	20.0	20.0	20.0
	3000RPM	0.70	0.84	1.16	1.39	1.74	2.09	2.32	2.90	3.48	4.18	4.18	5.23	6.27	7.53	10.46	11.28	14.1	16.91	18.79	20.0	20.0	20.0	20.0	20.0

Z5BLD120-□GU-30S/5GU□KB gearmotor allowable torque (Unit: N.m)

Model	Reduction ratio	Motor speed																							
		3	3.6	5	6	7.5	9	10	12.5	15	18	20	25	30	36	50	60	75	90	100	120	150	180	200	
Z5BLD120-□GU	200~1500RPM	1.45	1.74	2.41	2.90	3.62	4.34	4.35	5.44	6.53	7.83	7.87	9.83	11.8	14.2	19.7	20.0	20.0	20.0	20.0	20.0	20.0	20.0	20.0	20.0
	2000RPM	1.23	1.47	2.04	2.45	3.06	3.68	3.68	4.60	5.52	6.63	6.66	8.32	9.98	12.0	16.6	20.0	20.0	20.0	20.0	20.0	20.0	20.0	20.0	20.0
	2500RPM	1.11	1.34	1.86	2.23	2.78	3.34	3.35	4.18	5.02	6.02	6.05	7.56	9.08	10.9	15.1	18.2	20.0	20.0	20.0	20.0	20.0	20.0	20.0	20.0
	3000RPM	0.93	1.11	1.55	1.86	2.32	2.78	3.09	3.87	4.64	5.57	5.58	6.97	8.37	10.04	13.94	15.04	18.79	20.0	20.0	20.0	20.0	20.0	20.0	20.0

Note : The (Grey background area) in the table indicates that the rotation direction is same as the motor. (The torque under different speed and speed ratio is obtained under the SIEGMA standard.)

● L type gearbox

Z5BLD120-□GUL-30S/5GU□LC

□— Voltage 24/36/48/110/220

□— Reduction ratio

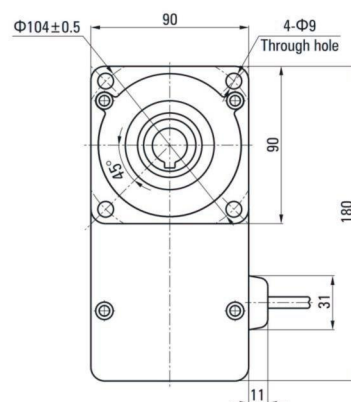
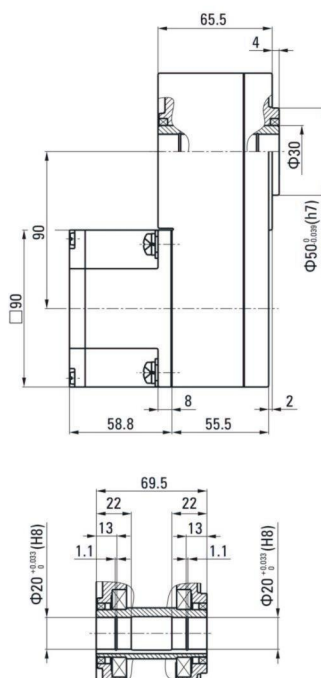
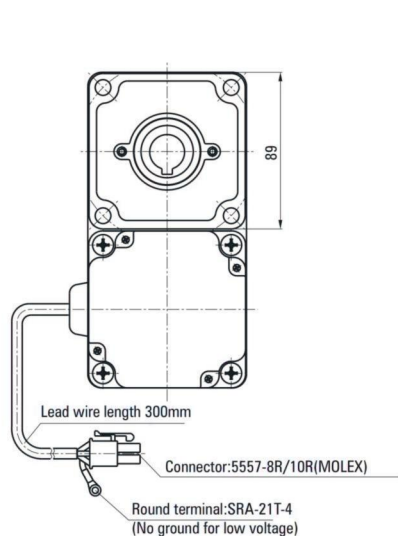

● The output shaft hole structure

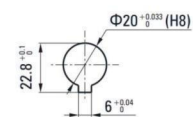

● Z5BLD60□GUL-30S/5GU□LC gearmotor allowable torque (Unit: N.m)

Reduction ratio	5	10	15	20	30	50	100	200
Motor speed								
200~1500RPM	1.09	2.18	3.26	4.35	6.53	10.9	21.8	43.5
2000RPM	0.92	1.84	2.76	3.68	5.52	9.20	18.4	36.8
2500RPM	0.84	1.67	2.51	3.35	5.02	8.37	16.7	33.5
3000RPM	0.70	1.39	2.09	2.79	4.18	6.97	13.94	27.89

● Z5BLD90□GUL-30S/5GU□LC gearmotor allowable torque (Unit: N.m)

Reduction ratio	5	10	15	20	30	50	100	200
Motor speed								
200~1500RPM	1.63	3.26	4.90	6.53	9.79	16.3	32.6	65.3
2000RPM	1.38	2.76	4.14	5.52	8.28	13.8	27.6	55.2
2500RPM	1.25	2.51	3.76	5.02	7.53	12.5	25.1	50.2
3000RPM	1.05	2.09	3.14	4.18	6.27	10.46	20.91	41.83

● Z5BLD120□GUL-30S/5GU□LC gearmotor allowable torque (Unit: N.m)

Reduction ratio	5	10	15	20	30	50	100	200
Motor speed								
200~1500RPM	2.41	4.83	7.24	9.65	13.1	21.8	43.5	68.0
2000RPM	2.04	4.08	6.13	8.17	11.0	18.4	36.8	66.6
2500RPM	1.86	3.71	5.57	7.43	10.0	16.7	33.5	60.5
3000RPM	1.39	2.79	4.18	5.58	8.37	13.94	27.89	55.77

Note : All gearbox output turn direction in form are opposite motor turn direction. (The torque under different speed and speed ratio is obtained under the SIEGMA standard.)

● Arc cone right angle speed reducer motor

Z5BLD120-GU-30S/5GURC — Voltage 24/36/48/110/220
 — Reduction ratio

Z5BLD120-GU-30S/5GURT — Voltage 24/36/48/110/220
 — Reduction ratio

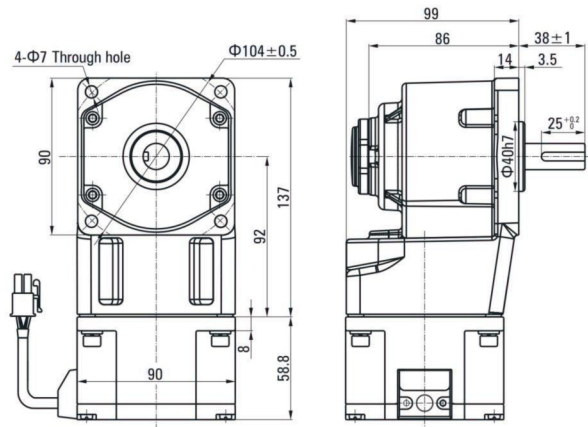
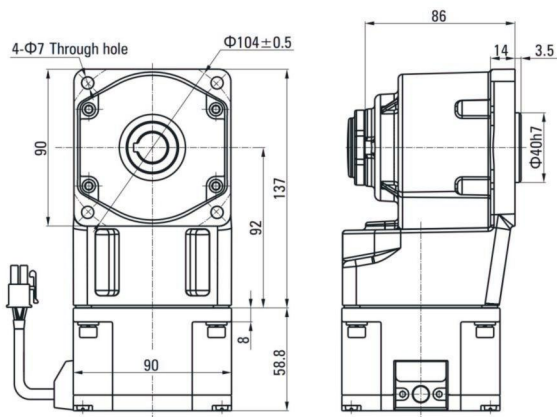

● The output shaft hole structure

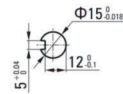
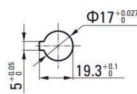

● Z5BLD60-GU-30S/5GURC/RT gearmotor allowable torque (Unit: N.m)

Model	Reduction ratio	Motor speed																	
		7.5	9	10	12.5	15	18	20	25	30	36	50	60	75	90	100	120	150	180
Z5BLD60- <input checked="" type="checkbox"/> GU	200~1500RPM	1.81	2.17	2.41	3.02	3.62	4.34	4.35	5.44	6.53	7.83	9.83	10.0	10.0	10.0	10.0	10.0	10.0	10.0
	2000RPM	1.53	1.84	2.04	2.55	3.06	3.68	3.68	4.60	5.52	6.63	8.32	9.98	10.0	10.0	10.0	10.0	10.0	10.0
	2500RPM	1.39	1.67	1.86	2.32	2.78	3.34	3.35	4.18	5.02	6.02	7.56	9.08	10.0	10.0	10.0	10.0	10.0	10.0
	3000RPM	0.95	1.13	1.26	1.58	1.89	2.27	2.52	3.15	3.78	5.02	6.97	8.37	10.0	10.0	10.0	10.0	10.0	10.0

● Z5BLD90-GU-30S/5GURC/RT gearmotor allowable torque (Unit: N.m)

Model	Reduction ratio	Motor speed																	
		7.5	9	10	12.5	15	18	20	25	30	36	50	60	75	90	100	120	150	180
Z5BLD90- <input checked="" type="checkbox"/> GU	200~1500RPM	2.72	3.26	3.62	4.53	5.43	6.52	6.53	8.16	9.79	11.8	14.7	17.7	20.0	20.0	20.0	20.0	20.0	20.0
	2000RPM	2.30	2.76	3.06	3.83	4.59	5.51	5.52	6.90	8.28	9.94	12.5	15.0	18.7	20.0	20.0	20.0	20.0	20.0
	2500RPM	2.09	2.51	2.78	3.48	4.18	5.01	5.02	6.27	7.53	9.04	11.3	13.6	17.0	20.0	20.0	20.0	20.0	20.0
	3000RPM	1.42	1.70	1.89	2.36	2.84	3.40	3.78	4.73	5.67	7.53	10.46	12.55	15.69	18.82	20.0	20.0	20.0	20.0

● Z5BLD120-GU-30S/5GURC/RT gearmotor allowable torque (Unit: N.m)

Model	Reduction ratio	Motor speed																	
		7.5	9	10	12.5	15	18	20	25	30	36	50	60	75	90	100	120	150	180
Z5BLD120- <input checked="" type="checkbox"/> GU	200~1500RPM	3.62	4.34	4.35	5.44	6.53	7.83	7.87	9.83	11.8	14.2	19.7	20.0	20.0	20.0	20.0	20.0	20.0	20.0
	2000RPM	3.06	3.68	3.68	4.60	5.52	6.63	6.66	8.32	9.98	12.0	16.6	20.0	20.0	20.0	20.0	20.0	20.0	20.0
	2500RPM	2.78	3.34	3.35	4.18	5.02	6.02	6.05	7.56	9.08	10.9	15.1	18.2	20.0	20.0	20.0	20.0	20.0	20.0
	3000RPM	1.89	2.27	2.52	3.15	3.78	4.54	5.04	6.30	7.56	10.04	13.94	16.73	20.0	20.0	20.0	20.0	20.0	20.0

Note : The (Grey background area) in the table indicates that the rotation direction is same as the motor. (The torque under different speed and speed ratio is obtained under the SIEGMA standard.)

104 SERIES OF BRUSHLESS DC MOTOR

Basic characteristics of motor

- 200W (DC power supply is suitable for 24VDC/36VDC/48VDC)

Rated power (Continuous)	W	200 (200W/400W)			
Rated speed	r/min	3000			
Rated torque	N.m	0.636			
Instantaneous maximum torque	N.m	0.955			
Rotor moment of inertia	J: 10^{-4} kg.m ²	0.460			
Speed control range	RPM	High pressure 200-2500RPM (Low pressure 200-3000RPM)			
Speed control range	On load	Below $\pm 1\%$: Condition 0~rated torque, rated speed, rated voltage, room temperature			
	On voltage	Below $\pm 1\%$: Condition rated voltage $\pm 10\%$, rated speed, rated load, room temperature			
	On temperature	Below $\pm 1\%$: Conditions of ambient temperature $-10^{\circ}\text{C} \sim +40^{\circ}\text{C}$ rated voltage, rated load and rated speed			
Power input	Rated voltage	V	Single phase 110V	Single phase 220V	36VDC (Optional 48VDC)
	Voltage tolerance range		$\pm 10\%$		
	Frequency	Hz	50/60		/
	Frequency tolerance range		$\pm 5\%$		
	Rated input current	A	4.7	2.4	7.5
	Instantaneous maximum input current	A	9.0	4.8	11.5

Round shaft type only motor

- Z6BLD200-□A-30S □— Voltage 24/36/48/110/220

- Z6BLD200-220A-30S Diagram (SIEGMA standard drive)

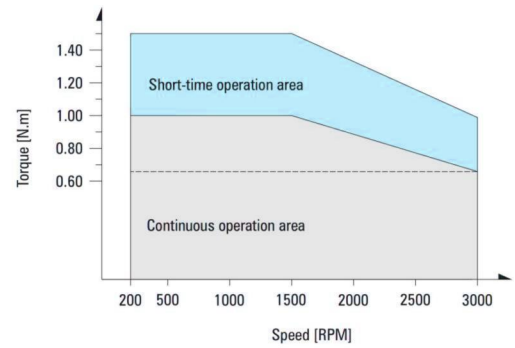
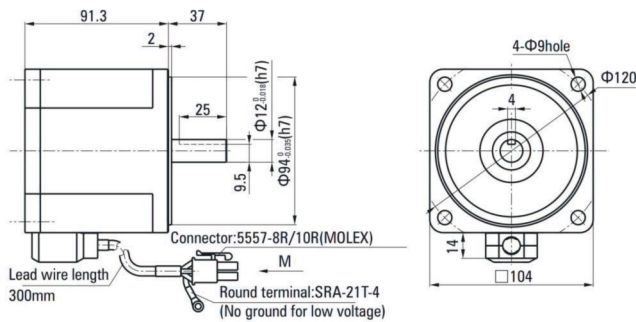

- Low voltage wire plughole corresponding signal explanation

- High voltage wire plughole corresponding signal explanation

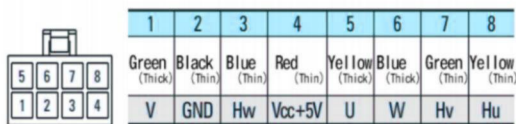

200W

Parallel shaft gearbox

Z6BLD200-□GU-30S/6GU□K

□ — Voltage 24/36/48/110/220

□ — Reduction ratio

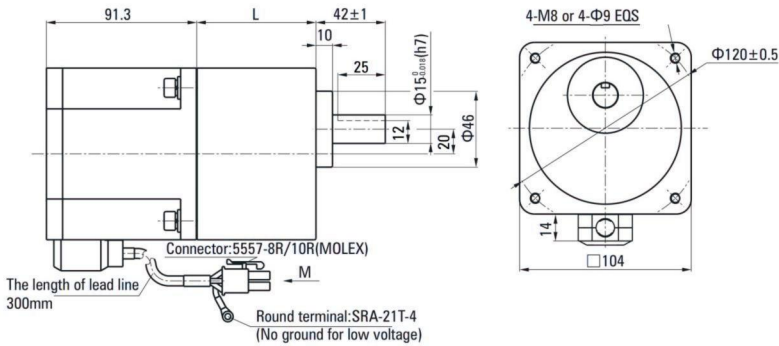

Key · Keyway

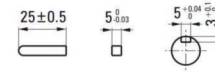

Gearhead model	Gear ratio	L Dimension
6GU□K	3~200	72

□ means gearbox ratio

Z6BLD200-□GU-30S/6GU□K gearmotor allowable torque (Unit: N.m)

Model	Reduction ratio	Motor speed																				
		3	3.6	5	6	7.5	9	12.5	15	18	25	30	36	50	60	75	90	100	120	150	180	200
Z6BLD200-□GU	200~1500RPM	2.41	2.90	4.02	4.83	6.03	7.24	9.06	10.9	13.1	16.4	19.7	23.6	32.8	39.3	40.0	40.0	40.0	40.0	40.0	40.0	40.0
	2000RPM	2.04	2.45	3.40	4.08	5.11	6.13	7.67	9.20	11.0	13.9	16.6	20.0	27.7	33.3	40.0	40.0	40.0	40.0	40.0	40.0	40.0
	2500RPM	1.86	2.23	3.09	3.71	4.64	5.57	6.97	8.37	10.0	12.6	15.1	18.2	25.2	30.3	37.8	40.0	40.0	40.0	40.0	40.0	40.0
	3000RPM	1.55	1.86	2.58	3.09	3.87	4.64	5.81	6.97	8.37	10.44	12.53	15.04	20.88	25.06	31.32	37.59	40.0	40.0	40.0	40.0	40.0

Z6BLD400-□GU-30S/6GU□K gearmotor allowable torque (Unit: N.m)

Model	Reduction ratio	Motor speed																				
		3	3.6	5	6	7.5	9	12.5	15	18	25	30	36	50	60	75	90	100	120	150	180	200
Z6BLD400-□GU	200~1500RPM	4.82	5.80	8.04	9.66	12.06	14.48	18.12	21.8	26.2	32.8	39.4	40.0	40.0	40.0	40.0	40.0	40.0	40.0	40.0	40.0	40.0
	2000RPM	4.08	4.90	6.80	8.16	10.22	12.26	15.34	18.4	22.0	27.8	33.2	40.0	40.0	40.0	40.0	40.0	40.0	40.0	40.0	40.0	40.0
	2500RPM	3.72	4.46	6.18	7.42	9.28	11.14	13.94	16.74	20.0	25.2	30.2	36.4	40.0	40.0	40.0	40.0	40.0	40.0	40.0	40.0	40.0
	3000RPM	3.09	3.71	5.16	6.19	7.74	9.28	11.62	13.94	16.73	20.88	25.06	30.07	40.0	40.0	40.0	40.0	40.0	40.0	40.0	40.0	40.0

Note : The □ (Grey background area) in the table indicates that the rotation direction is same as the motor. (The torque under different speed and speed ratio is obtained under the SIEGMA standard.)

L type gearbox

Z6BLD200-□GUL-30S/6GU□LC

□ — Voltage 24/36/48/110/220

□ — Reduction ratio

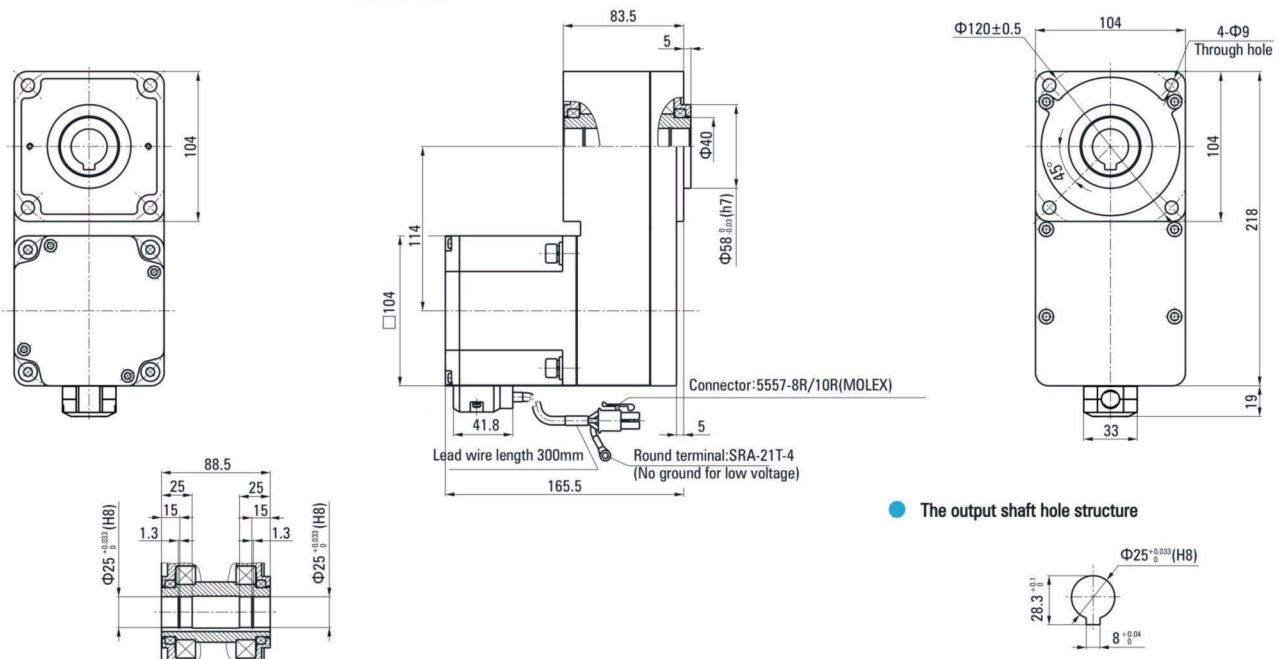

The output shaft hole structure

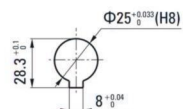

● Z6BLD200-□GUL-30S/6GU□LC gearmotor allowable torque (Unit: N.m)

Reduction ratio	5	15	20	30	40	50	100
Motor speed							
200~1500RPM	4.02	12.1	16.10	21.80	32.20	40.20	80.40
2000RPM	3.40	10.2	13.60	20.40	27.20	34.00	68.00
2500RPM	3.09	9.27	12.36	18.54	24.72	30.90	61.80
3000RPM	2.32	6.96	9.280	13.92	18.56	23.20	46.40

● Z6BLD400-□GUL-30S/6GU□LC gearmotor allowable torque (Unit: N.m)

Reduction ratio	5	15	20	30	40	50	100
Motor speed							
200~1500RPM	8.04	24.20	32.20	43.60	64.40	80.40	120.0
2000RPM	6.80	20.40	27.20	40.80	54.40	68.00	120.0
2500RPM	6.18	18.54	24.72	37.08	49.44	61.80	120.0
3000RPM	4.64	13.92	18.56	27.84	37.12	46.40	92.80

Note : All gearbox output turn direction in form are opposite motor turn direction. (The torque under different speed and speed ratio is obtained under the SIEGMA standard.)

● Arc cone right angle speed reducer motor

Z6BLD200-□GU-30S/6GU□RC □—Voltage 24/36/48/110/220
□—Reduction ratio

Z6BLD200-□GU-30S/6GU□RT □—Voltage 24/36/48/110/220
□—Reduction ratio

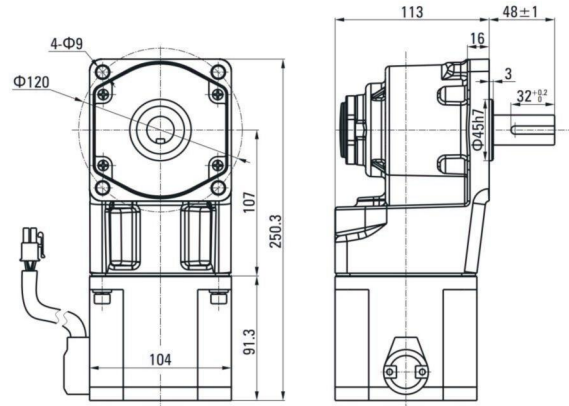
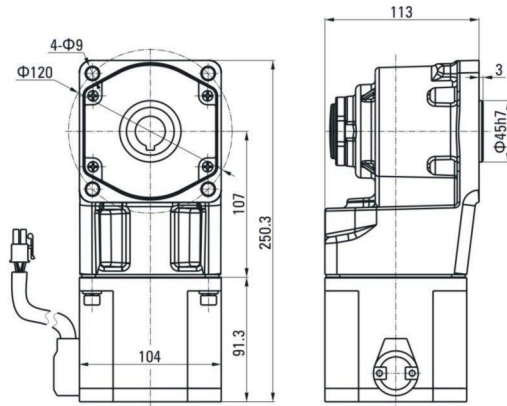

● The output shaft hole structure

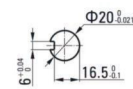
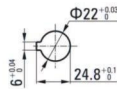

● Z6BLD200-□GU-30S/6GU□RC/RT gearmotor allowable torque (Unit: N.m)

Model	Reduction ratio	7.5	9	12.5	15	18	25	30	36	50	60	75	90	100	120	150	180	200
		Motor speed																
Z6BLD200-□GU	200~1500RPM	6.03	7.24	9.06	10.9	13.1	16.4	19.7	23.6	32.8	39.3	40.0	40.0	40.0	40.0	40.0	40.0	40.0
	2000RPM	5.11	6.13	7.67	9.20	11.0	13.9	16.6	20.0	27.7	33.3	40.0	40.0	40.0	40.0	40.0	40.0	40.0
	2500RPM	4.64	5.57	6.97	8.37	10.0	12.6	15.1	18.2	25.2	30.3	37.8	40.0	40.0	40.0	40.0	40.0	40.0
	3000RPM	3.15	3.78	5.25	6.30	7.56	10.51	12.61	15.13	23.24	27.89	34.86	40.0	40.0	40.0	40.0	40.0	40.0

● Z6BLD400-□GU-25S/6GU□RC/RT gearmotor allowable torque (Unit: N.m)

Model	Reduction ratio	7.5	9	12.5	15	18	25	30	36	50	60	75	90	100	120	150	180	200
		Motor speed																
Z6BLD400-□GU	200~1500RPM	12.06	14.48	18.12	21.8	26.2	32.8	39.4	40.0	40.0	40.0	40.0	40.0	40.0	40.0	40.0	40.0	40.0
	2000RPM	10.22	12.26	15.34	18.4	22.0	27.8	33.2	40.0	40.0	40.0	40.0	40.0	40.0	40.0	40.0	40.0	40.0
	2500RPM	9.28	11.14	13.94	16.74	20.0	25.2	30.2	36.4	40.0	40.0	40.0	40.0	40.0	40.0	40.0	40.0	40.0
	3000RPM	6.30	7.56	10.51	12.61	15.13	21.01	25.21	30.25	40.0	40.0	40.0	40.0	40.0	40.0	40.0	40.0	40.0

Note : The □ (Grey background area) in the table indicates that the rotation direction is same as the motor. (The torque under different speed and speed ratio is obtained under the SIEGMA standard.)

86 SERIES OF BRUSHLESS DC MOTOR(GU TYPE)

Parallel shaft gearbox

Z55BLD200-GUL-30S/5GULC — Voltage 24/36/48
— Reduction ratio

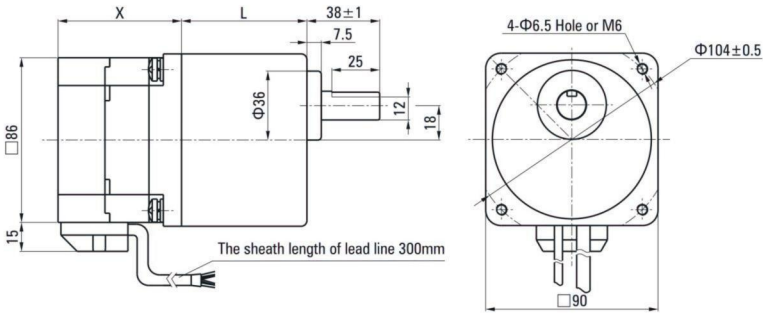

Key - Keyway



L type gearbox

Z55BLD200-GUL-30S/5GULC — Voltage 24/36/48
— Reduction ratio

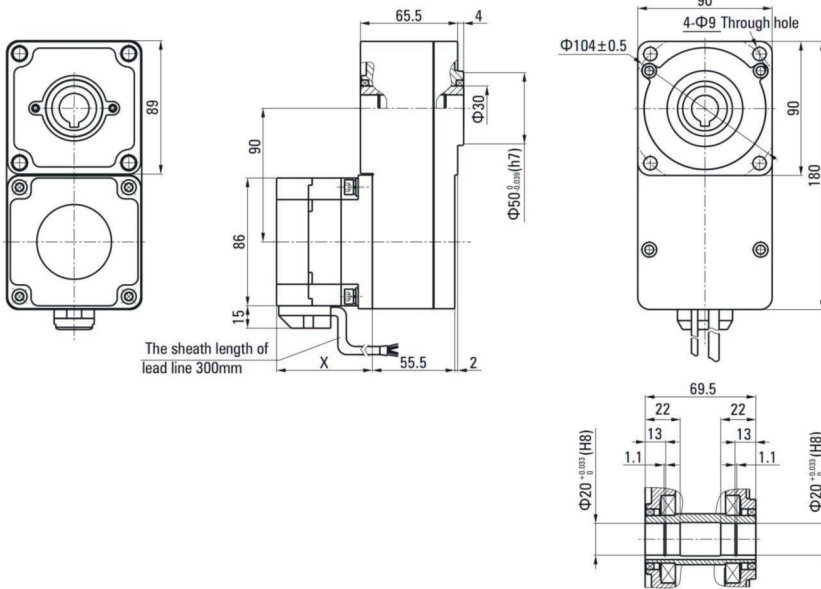

Motor power band

Rated power (W)	Rated speed (RPM)	Extent X (mm)
200	3000	64.5
300	3000	74.5
400	3000	84.5
500	3000	94.5
600	3000	105.5
750	3000	130.0

Gearhead model	Gear ratio	L Dimension
5GU <input type="checkbox"/> KB	3~200	65.5

means gearbox ratio

Decimal gearbox

5GUXK
—Velocity ratio value, generally 10

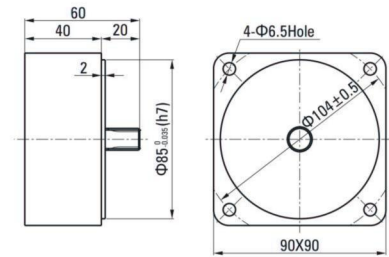

The output shaft hole structure

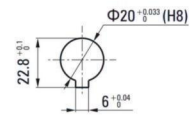

120 SERIES OF BRUSHLESS DC MOTOR(GU TYPE)

750W

Parallel shaft gearbox

Z7BLD750-GV-30S/7GUV — Voltage 48/220
— Reduction ratio

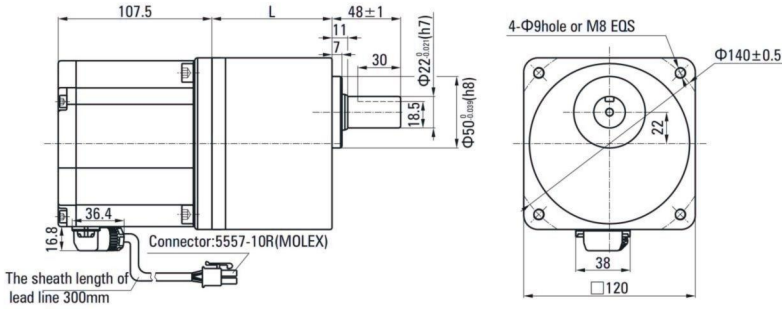

Key · Keyway

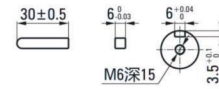

Gearhead model	Gear ratio	L Dimension
7GU <input type="checkbox"/> V	5~50	84

● means gearbox ratio

Z7BLD750-GV-30S/7GUV gearmotor allowable torque (Unit: N.m)

Model	Motor speed	Reduction ratio					
		5	10	15	20	30	50
Z7BLD750- <input type="checkbox"/> GV	200~1500RPM						
	2000RPM						
	2500RPM	11.60	23.21	31.37	41.83	62.74	100.00
	3000RPM	9.67	19.34	26.14	34.86	52.29	87.14

Z7BLD750-GUL-30S/7GUL gearmotor allowable torque (Unit: N.m)

Model	Motor speed	Reduction ratio							
		5	10	15	20	25	30	50	100
Z7BLD750- <input type="checkbox"/> GUL	200~1500RPM	17.43	34.86	52.29	69.72	87.14	104.57	174.00	200.00
	2000RPM	13.07	26.14	39.21	52.29	65.36	78.43	130.72	200.00
	2500RPM	10.46	20.91	31.37	41.83	52.29	62.74	104.57	200.00
	3000RPM	8.71	17.43	26.14	34.86	43.57	52.29	87.14	174.00

Note : The (Grey background area) in the table indicates that the rotation direction is same as the motor. (The torque under different speed and speed ratio is obtained under the SIEGMA standard.)

L type gearbox

Z7BLD750-GUL-30S/7GUL — Voltage 48/220 — Reduction ratio

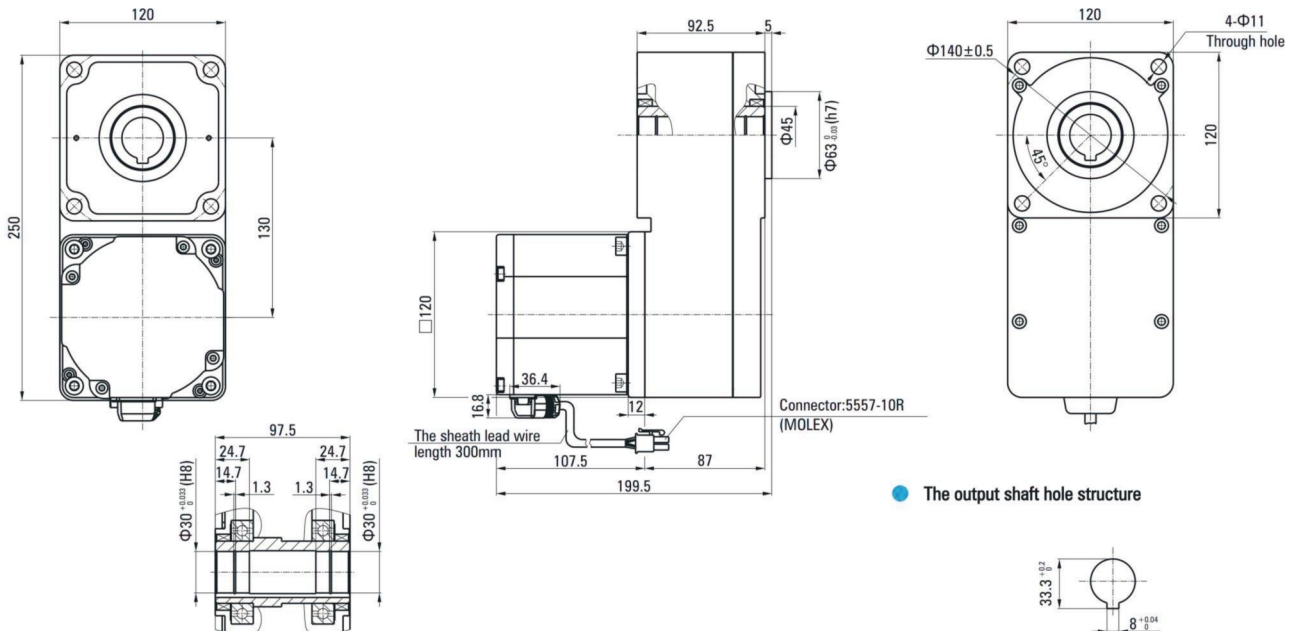

The output shaft hole structure

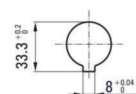

C10 SERIES BRUSHLESS DRIVERS

Z BLD • C10 — 120 L/H/S2 D/X
① ② ③ ④ ⑤ ⑥

①	Company	SIEGMA	
②	Type	BLD: Motor driver	
		DRV: Driver and related products	
③	Version	C10: C10、C13 Series	
④	Power	120	200
		120W	200W
⑤	Voltage	L: Low voltage DC24V~48V	L2: Low voltage DC24V
		H/S2: High voltage AC220V/50Hz	
⑥	Feature	D: With display	
		X: With extended function	

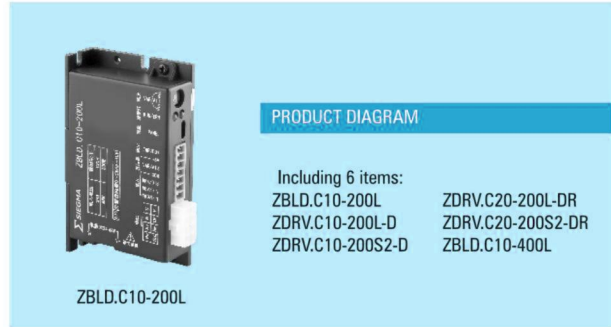

Features of C10 series brushless motor driver

- Digital display: 4-digit digital tube display: running status, set speed, running speed, fault indication.
- Stable speed operation: adopt speed closed-loop control (control accuracy $\pm 0.5\%$).
- Input and output: 2 groups of NPN type digital input interfaces (forward and reverse); 1 group of open-drain digital output interfaces (fault output).
- Speed setting: Set the running speed through the panel knob, which is convenient and quick.
- Perfect fault detection and protection functions: 1. Various fault detections such as undervoltage, overvoltage, overcurrent, overload, locked rotor, short circuit, phase loss, overtemperature, etc.; 2. After the failure occurs, the drive carries out corresponding protection actions according to the type of failure; 3. The fault information can be displayed through the digital tube.
- Extended functions include: expansion of 3 sets of NPN digital input interfaces, 1 set of analog quantity interfaces, and 1 set of 485 communication control interfaces.

C20 SERIES BRUSHLESS DRIVERS

Z BLD • C20 — 120 L/H/S2 C/R
 ① ② ③ ④ ⑤ ⑥

①	Company	SIEGMA		
②	Type	BLD: Brushless driver		
		DRV: Driver and related products		
③	Version	C20: C20 Series		
④	Power	120	400	800
		120W	400W	800W
⑤	Voltage	L: DC24V~48V (L1:12V; L2:24V; L3:36V; L4:48V)		
		H/S2: High voltage AC220V		
⑥	Feature	C: Can communication		
		R: 485 communication		

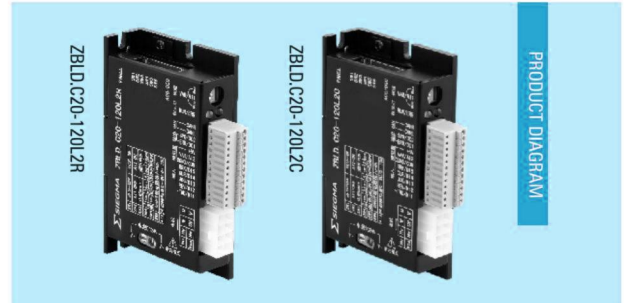

Features of C20 series brushless motor driver

- A variety of operating modes: open-loop, closed-loop (control accuracy $\pm 0.5\%$).
- Multiple commands given: multi-function input terminal control, communication control, external keyboard control.
- Various speed settings: built-in knob, external analog voltage (0~5/10V) or PWM (3k~10kHz), HDI high-speed pulse input 0~20KHZ frequency setting, communication setting, keyboard setting, multi-speed, Simple PLC control (depending on the specific model).
- Acceleration/deceleration control: 0.3s~10s range, can be adjusted by knob, communication adjustment and keyboard adjustment.
- Electronic brake function: realize fast electromagnetic braking.
- Multi-function input interface: 5 digital inputs, which can be customized by the user through the keyboard: forward, reverse, jog, free stop, electronic brake, multi-speed and other functional inputs.
- Multi-function output interface: 2 digital outputs can be customized by the user through the keyboard: running, fault, speed output, overload warning, virtual terminal output and other functional outputs.
- Perfect fault detection and protection functions: under-voltage, over-voltage, over-current, overload, locked-rotor, short-circuit, phase-loss, over-temperature and other fault detection; after a fault occurs, the driver performs corresponding protection actions according to the type of fault; Fault information can be displayed by LED lights or keyboard.

Keyboard accessories: The external keyboard can be used to set parameters, read status, realize keyboard control, multi-function input, multi-function output, multi-speed, simple PLC and other functions.

C30 SERIES BRUSHLESS DRIVERS

Z DRV • C30 — 200 L/S2 B/C/R
 ① ② ③ ④ ⑤ ⑥

①	Company	SIEGMA		
②	Type	DRV: Driver and related products		
③	Version	C30: C30 Series		
④	Power	120	200	400
		120W	200W	400W
⑤	Voltage	L: DC24V~48V (L1:12V; L2:24V; L3:36V; L4:48V)		
		S2: High voltage AC220V		
⑥	Feature	B: With brake		
		R: With 485 communication		
		C: With Can communication		
		D: With display		

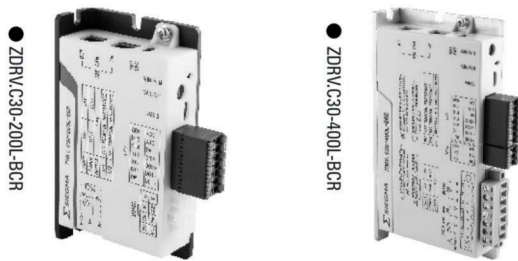

Features of C30 series brushless motor driver

- Multiple operation modes: open-loop, closed-loop (control accuracy $\pm 0.5\%$).
- Multiple control modes: four-quadrant operation, zero-speed hold, torque/speed mode, zero-speed positioning.
- A variety of command given: multi-function input terminal control (support NPN, PNP input); communication control; external keyboard control.
- Various speed settings: built-in knob, external analog voltage (0~5/10V) or PWM (3k~10kHz), HDI high-speed pulse input 0~20KHZ frequency setting, communication setting, keyboard setting, multi-speed, Simple PLC control (depending on the specific model).
- Acceleration/deceleration control: 0.3s~10s can be adjusted by communication and keyboard.
- Electronic brake function: realize fast electromagnetic braking, and external energy consumption resistance braking can be realized.
- Multi-function input interface: 5 digital inputs (supports NPN and PNP), which can be customized by the user through the keyboard: forward, reverse, jog, free stop, electronic brake, multi-speed and other functional inputs.
- Multi-function output interface: 2 digital outputs can be customized by the user through the keyboard: running, fault, speed output, overload warning, virtual terminal output and other functional outputs.
- Perfect fault detection and protection functions: under-voltage, over-voltage, over-current, overload, locked rotor, short-circuit, lack of etc. fault detection; after a fault occurs, the driver will perform corresponding protection actions according to the type of fault; fault information can be passed through LED lights or keyboard display.

COMMON SPECIFICATIONS

Permissible overhung load and permissible thrust load of motor

Permissible overhung load

Motor		Permissible overhung load	
Motor frame size □(mm)	Output shaft diameter □(mm)	Distance from shaft end	
		10mm	20mm
42	5	40	-
60	6	50	110
70	6	40	60
80	8	90	140
	10	110	120
90	10	140	200
	12	240	270
100	14	320	350

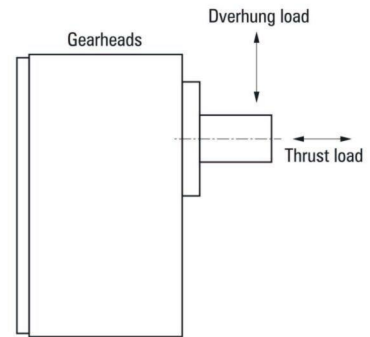

- Permissible thrust load.
- Avoid thrust loads as much as possible. If thrust load is unavoidable, keep it to half or less of the motor mass.

Allowable suspension load of motor • Allowable axial load

Model	Gear ratio	Maximum permissible torque N.m	Permissible overhung load N		Permissible thrust load N
			10mm from shaft end	20mm from shaft end	
2GN□K	3~18	3.0	50	80	30
	25~200		120	180	
4GN□K	3~18	8.0	100	150	50
	25~200		200	300	
5GN□K	3~18	10	250	350	100
	25~200		300	450	
5GU□KB 5GU□K	3~9	20	400	500	150
	12.5~18		450	600	
	25~200		500	700	
6GU□K	3~200	40	1100	1500	300

Permissible load inertia for gearhead J

- When a high load inertia (J) is connected to a gearhead, high torque is exerted instantaneously on the gearhead when starting up in frequent, discontinuous operations (or when stopped by an electromagnetic brake, or when stopped instantaneously by a brake pack). Excessive impact loads can cause the gearhead or motor damage.
- The table below gives values for permissible load inertia on the motor shaft. Use the motor and gearhead within these parameters. The permissible inertial load value shown for three-phase motors is the value when reversing after a stop.
- The permissible load inertia (J) on the gearhead output shaft is calculated with the following equation.
- The life of the gearhead when operating at the permissible inertial load with instantaneous stops of the motors with electromagnetic brakes, brake packs or speed control motors is at least 2 million cycles.

Permissible load inertia for gear head output shaft

Gear ratio 1/3 ~ 1/50 JG=JM×I
 Gear ratio 1/60 or high JG=JM×2500

JG: Permissible load inertia gearhead output shaft J (×10kg.m²)
 JM: Permissible load inertia at the motor shaft J (×10kg.m²)
 I: Gear ratio (Example: i=3 means the gear ratio or 1/3)

Permissible load inertia at the motor shaft

No. of phase	Motor frame size	Output power	Permissible load inertia at the motor shaft	
			J(×10 ⁻⁴ kg.m ²)	GD ² (kg.m ²)
Single-phase	42	1W, 3W	0.016	0.07
	60	3W※, 6W	0.062	0.25
	70	6W※, 15W	0.14	0.52
	80	10W※, 25W	0.31	1.2
	90	20W※, 40W	0.75	3
		60W	1.1	4.6
		90W	1.1	4.6
	100	120W	1.1	4.6
		120W	2	8
		140W	2	8
180W	2	8		
Three-phase	60	6W	0.062	0.25
	70	15W	0.14	0.52
	80	25W	0.31	1.2
	90	40W	0.75	3
		60W	1.1	4.6
		90W	1.1	4.6
	100	120W	1.1	4.6
		120W	2	8
		140W	2	8
	180W	2	8	
DC Power	60	6W, 10W, 15W	0.062	0.25
	70	15W	0.14	0.52
	80	25W, 40W	0.31	1.2
	90	40W	0.75	3
		60W	1.1	4.6
		90W	1.1	4.6
	100	120W	1.1	4.6
		250W	2	8

※Output power for torque motors

The calculation for the permissible torque of gearhead

Permissible torque for some products are omitted. In that case, use the equation below to calculate the permissible torque.
 Permissible torque TG=TM×i×η

TG: Permissible torque of gearhead TM: Motor torque
 i: Gear ratio gearhead η: Gearhead efficiency

Gearhead efficiency

Model	Gear ratio																			
	3	3.6	5	6	7.5	9	12.5	15	18	25	30	36	50	60	75	90	100	120	150	180
2GN□K	81%																			
4GN□K 4GN□RC/RT	73%																			
5GN□K	66%																			
5GU□KB 5GU□RC/RT	59%																			
6GU□K 6GU□RC/RT	66%																			

Model	Gear ratio							
	5	10	15	20	30	50	100	200
2GN□L	83%	89%						
4GN□L	74%	89%						
5GU□L	74%	89%						
6GU□L	74%	89%						

ACCESSORIES

Motor • Gearhead bracket brackets

The dedicated mounting bracket is designed for easy installation and fixation of electric motors and reducers. It is a high-strength product suitable for large power electric motors and reducers.

The mounting bracket is pre-drilled with holes; please use the screws provided with the reducer to assemble the electric motor and reducer together. When installing the electric motor alone, please use separate mounting screws.



Motor frame size: 80mm

Model: ZD4M5 Weight: 200g Material: Aluminum

Applicable products: 4GN Gearhead

Motor with the frame size of □80mm

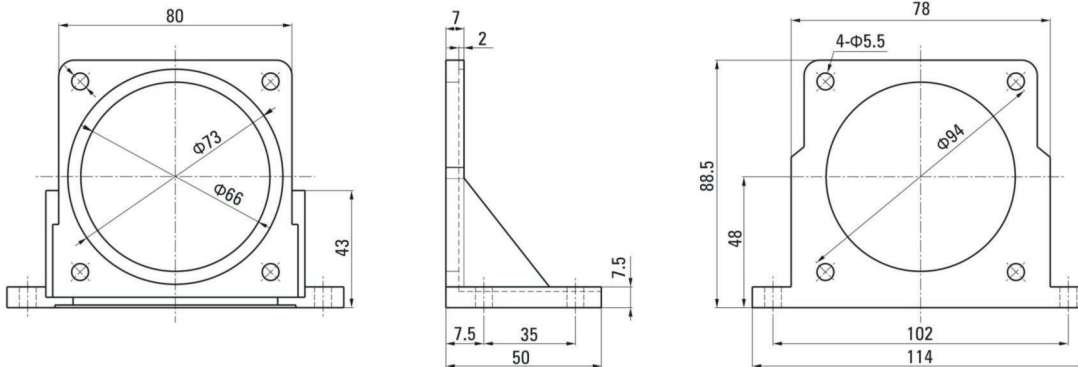

Motor frame size: 90mm

Model: SIGMA 5M5 Weight: 270g Material: Aluminum

Applicable products: 5GN, 5GU Gearhead

Motor with the frame size of □90mm

